

LIVERMORE AMADOR VALLEY TRANSIT AUTHORITY  
(LAVTA)

REQUEST FOR PROPOSALS

FOR

**On-Call Bus Shelter Installation, Removal and  
Related Services**

RFP# 2017-18

LIVERMORE AMADOR VALLEY TRANSIT AUTHORITY  
1362 Rutan Court, Suite 100  
Livermore, CA 94551

November 16, 2017

Key RFP Dates

<b>Date of Issuance:</b>	<b>November 16, 2017</b>
<b>Pre-Proposal Conference</b>	<b>December 5, 2017 10:00 am PST</b>
<b>Written Questions/Request Due:</b>	<b>December 11, 2017 4:00 pm PST</b>
<b>Responses to Questions/Requests Due:</b>	<b>December 13, 2017</b>
<b>Proposals Due:</b>	<b>December 20, 2017 2:00 pm PST</b>
<b>Contract Award (estimated):</b>	<b>February 5, 2017</b>
<b>Contract Execution (estimated):</b>	<b>February 12, 2017</b>

Contact Information:  
Jennifer Yeamans  
Senior Grants, Project Management & Contract Specialist  
(925) 455-7555  
jyeamans@lavta.org

November 16, 2017

**SUBJECT: NOTICE OF REQUEST FOR PROPOSALS**  
**On-Call Bus Shelter Installation, Removal and Related Services**

**RFP #2017-18**

The Livermore Amador Valley Transit Authority (LAVTA), operator of the Wheels bus system, is accepting proposals from qualified firms for On-Call Bus Shelter Installation, Removal and Related Services as defined in the Request for Proposal #2017-18.

This project shall include the furnishing of all labor and services as set forth in the Scope of Work section of the Request for Proposal (RFP).

All Questions and Requests for Clarification must be submitted in writing by **December 11, 2017, at 4:00 p.m. Proposals must be received in the LAVTA Administrative Offices by 2:00 p.m. on December 20, 2017. No proposals will be accepted after this time and date.** Any proposal or amendment to proposal received after the closing time will be returned unopened to the sender. No Proposer may withdraw its proposal for a period of one hundred twenty (120) days after the opening of proposals. Each Proposer will be notified of award of contract, if award is made. LAVTA reserves the right to reject any and all proposals, or to waive any irregularities or informalities in any proposal or in the proposal procedure, or to postpone the proposal opening for good cause.

Proposals shall be submitted to the following:

**Livermore Amador Valley Transit Authority**  
**1362 Rutan Court, Suite 100**  
**Livermore, CA 94551**  
**Attention: Jennifer Yeamans, Project Manager**

Full compliance with all Safety and Health Standards, Equal Employment Opportunity, and Americans with Disabilities Act laws and regulations will be required of the Proposer.

This is a public works contract under the Labor Code. In accordance with section 1720 et seq. of the Labor Code, the general prevailing wage rates as established by the Director of the California Department of Industrial Relations will apply. The prevailing wage rates established by the State Director of Industrial Relations are available on the State of California's website at <http://www.dir.ca.gov/> or can be obtained by mail addressed to: Prevailing Wage Unit, Division of Labor Statistics and Research, Department of Industrial Relations, P.O. Box 603, San Francisco, CA 94101.

No contractor or subcontractor may be listed on a bid proposal for a public works project unless registered with Department of Industrial Relations (DIR) pursuant to Labor Code section 1725.5 at the time of bid. Additionally, no contractor or subcontractor may be awarded a contract for public works unless registered with DIR pursuant to California Labor Code section 1725.5. Each bidder must submit proof of contractor registration with DIR (e.g. a hard copy of the relevant page of the DIR's database found at: <https://efiling.dir.ca.gov/PWCR/Search>). This Contract is subject to monitoring and enforcement by the DIR pursuant to Labor Code Section 1771.4.

LAVTA intends for this procurement to be primarily conducted electronically via distribution on the procurement page of [www.wheelsbus.com](http://www.wheelsbus.com); however, upon request, copies of the RFP may be obtained by contacting LAVTA at (925) 455-7555.

*/s/ Tamara Edwards*

Tamara Edwards  
Procurement Officer  
Livermore Amador Valley Transit Authority

November 16, 2017

Date

SECTION I

INSTRUCTIONS TO PROPOSERS

## SECTION I – Instructions to Proposers

### Table of Contents

1	REQUEST FOR PROPOSALS .....	I-1
2	EXAMINATION OF PROPOSAL DOCUMENTS.....	I-1
3	ADDENDA.....	I-1
4	AUTHORITY CONTACT .....	I-1
5	PRE-PROPOSAL CONFERENCE .....	I-1
6	QUESTIONS AND REQUESTS FOR CLARIFICATION .....	I-2
7	AUTHORITY RESPONSES.....	I-2
8	SUBMISSION OF PROPOSALS.....	I-2
9	IDENTIFICATION OF PROPOSALS.....	I-3
10	ACCEPTANCE OF PROPOSALS .....	I-3
11	PRE-CONTRACTUAL EXPENSES .....	I-3
12	JOINT OFFERS.....	I-4
13	PROTEST PROCEDURES.....	I-4
14	CONTRACT TYPE .....	I-4

## **SECTION I – Instructions to Proposers**

### **On-Call Bus Shelter Installation, Removal and Related Services**

#### **1 REQUEST FOR PROPOSALS**

The Livermore Amador Valley Transit Authority (“LAVTA” or “Authority”) seeks to retain on-call bus shelter installation, removal and related maintenance services. LAVTA will utilize the “Best Value” method of procurement, in conformance with applicable procurement guidelines. Respondents to this RFP should demonstrate an understanding of the work to be performed.

#### **2 EXAMINATION OF PROPOSAL DOCUMENTS**

The work to be performed under this contract consists of the furnishing of all labor, insurance, materials, and equipment necessary to perform the requirements specified in the Scope of Work, except for those materials to be supplied by LAVTA as specified in the Scope of Work. By submitting a proposal, Proposer represents that it has thoroughly examined and become familiar with the work required under this RFP and that it is capable of performing quality work to achieve the Livermore Amador Valley Transit Authority’s (“Authority” or “LAVTA”) objectives.

#### **3 ADDENDA**

Any Authority changes to the requirements will be made by written addendum to this RFP. Any written addenda issued pertaining to this RFP shall be incorporated into the terms and conditions of any resulting Agreement. The Authority will not be bound to any modifications to or deviations from the requirements set forth in this RFP as the result of oral instructions. Proposers shall acknowledge receipt of addenda in their proposals.

#### **4 AUTHORITY CONTACT**

All questions and/or contacts with LAVTA staff regarding this RFP are to be directed to the Project Manager:

Jennifer Yeaman  
Livermore Amador Valley Transit Authority  
1362 Rutan Court, Suite 100  
Livermore, CA 94551  
Phone: (925) 455-7555

#### **5 PRE-PROPOSAL CONFERENCE**

A non-mandatory Pre-Proposal Conference will be held beginning at 10:00 a.m. on December 5, 2017, at the LAVTA Administrative Offices, 1362 Rutan Court, Suite 100, Livermore, CA 94551. At this Conference, members of the Authority’s staff will be available to answer questions pertaining to the Contract Documents and Scope of Work.

The Conference should take approximately one hour. Attendance is not mandatory, but strongly encouraged to ensure Proposers are familiar with the Scope of Work and to allow an opportunity to visit prospective work sites and take measurements. Proposers must ensure that when viewing any shelter sites that they are not parked illegally or causing any traffic hazard whatsoever.

## 6 QUESTIONS AND REQUESTS FOR CLARIFICATION

Should a Proposer have questions concerning or require clarifications of this RFP, the Proposer shall notify the Authority in writing. Should it be found that the point in question is not clearly and fully set forth, the Authority will issue a written addendum clarifying the matter, which will be posted on the agency's website, [www.wheelsbus.com](http://www.wheelsbus.com).

### Submitting Request

- (a) All questions and/or requests for clarification must be put in writing and must be received by the Authority no later than 4:00 p.m. on December 11, 2017.
- (b) Request for clarification, questions and comments must be clearly labeled, "Written Questions." The Authority is not responsible for failure to respond to a request that has not been labeled as such.
- (c) Any of the following methods of delivering written questions are acceptable as long as the questions are received no later than the date and time specified above:
  - (1) U.S. Mail: Livermore Amador Valley Transit Authority, 1362 Rutan Court, Suite 100, Livermore, CA 94551.
  - (2) Personal Courier: Procurement Officer, 1362 Rutan Court, Suite 100, Livermore, CA 94551.
  - (3) Facsimile: The Authority's fax number is (925) 443-1375.
  - (4) E-Mail: [jyeamans@lavta.org](mailto:jyeamans@lavta.org).

## 7 AUTHORITY RESPONSES

Responses from the Authority will be posted on the Authority's website, [www.wheelsbus.com](http://www.wheelsbus.com), by December 13, 2017. LAVTA reserves the right to postpone this deadline for its own convenience.

## 8 SUBMISSION OF PROPOSALS

- (a) Date and Time - Proposals must be received in the LAVTA Administrative Offices at or before **2:00 p.m. on December 20, 2017**. Proposals received after the above-specified date and time will be returned to Proposers unopened.

- (b) Address - Proposals shall be submitted to the following:

**Livermore Amador Valley Transit Authority  
1362 Rutan Court, Suite 100  
Livermore, CA 94551  
Attn: Jennifer Yeamans, Project Manager**

## **9 IDENTIFICATION OF PROPOSALS**

Proposer shall submit five (5) originals of its proposal in a sealed box addressed as shown above, bearing the Proposer's name and address and clearly marked as follows:

**“On-Call Bus Shelter Installation, Removal and Related Services,  
RFP 2017-18”**

## **10 ACCEPTANCE OF PROPOSALS**

- (a) The Authority reserves the right to accept or reject any and all proposals, or any item or part thereof, or to waive any informalities or irregularities in proposals or proposal procedures.
- (b) The Authority reserves the right to withdraw or cancel this RFP at any time without prior notice and the Authority makes no representations that any contract will be awarded to any Proposer responding to this RFP.
- (c) The Authority reserves the right to postpone proposal openings for its own convenience.
- (d) The Authority reserves the right to request additional information to clarify any proposal.

## **11 PRE-CONTRACTUAL EXPENSES**

The Authority shall not, in any event, be liable for any pre-contractual expenses incurred by Proposer in the preparation of its proposal. Proposer shall not include any such expenses as part of its proposal.

Pre-contractual expenses are defined as expenses incurred by Proposer in:

1. Preparing its proposal in response to this RFP;
2. Submitting that proposal to the Authority;
3. Preparing and interviewing for the solicitation;
4. Giving a demonstration to the Authority;
5. Negotiating with the Authority on any matter related to this proposal; or



6. Any other expenses incurred by Proposer prior to date of award, if any of the Agreement.

## **12 JOINT OFFERS**

Where two or more firms desire to submit a single proposal in response to this RFP, they should do so on a prime-subcontractor basis rather than as a joint venture. The Authority intends to contract with a single firm rather than with multiple firms doing business as a joint venture.

## **13 PROTEST PROCEDURES**

Protests based upon the content of this Request for Proposals shall be filed in writing with Michael Tree, LAVTA Executive Director, within ten (10) calendar days after the Request for Proposals is first advertised. The protest must clearly specify in writing the grounds and evidence on which the protest is based. LAVTA shall issue a written decision on the protest prior to the opening of proposals. A protest may be renewed by refiling the protest within fifteen (15) calendar days after the mailing of the notice of the recommended award.

Any proposer may protest the recommended award on any ground not based upon the content of the Request for Proposals by filing a protest with the LAVTA Executive Director within fifteen (15) calendar days after the mailing of the notice of the recommended award. The protest must clearly specify in writing the grounds and evidence on which the protest is based. Protesters shall have an opportunity to appear and be heard before the board prior to final award of the contract.

Copies of the complete proposal protest procedure are available at the office of the Authority.

## **14 CONTRACT TYPE**

Following the completion of all contractual requirements, the Contractor shall provide the services within the approved scope, schedule and price as set forth in the Agreement. (See Appendix C - Sample Agreement).

SECTION II

SCOPE OF WORK

**SECTION II – Scope of Work**

**On-Call Bus Shelter Installation, Removal and Related Services**

**Table of Contents**

<b>1. INTRODUCTION.....</b>	<b>II-1</b>
<b>1.1 Request for Proposals.....</b>	<b>II-1</b>
<b>1.2 Scope of Work.....</b>	<b>II-1</b>
1.2.1 Background .....	II-1
1.2.2 Task Order Process.....	II-2
1.2.3 General.....	II-2
<b>1.3 Contract Period .....</b>	<b>II-3</b>
<b>2 ADDITIONAL REQUIREMENTS .....</b>	<b>II-4</b>
<b>2.1 Confidentiality .....</b>	<b>II-4</b>
<b>2.2 Conflict of Interest .....</b>	<b>II-4</b>

## **SECTION II – Scope of Work**

### **On-Call Bus Shelter Installation, Removal and Related Services**

#### **1. INTRODUCTION**

##### **1.1 Request for Proposals**

The Livermore Amador Valley Transit Authority (LAVTA) seeks the services of a qualified firm capable of providing on-call bus shelter installation, removal and related services for various projects.

LAVTA will utilize the “Best Value” method of procurement, in conformance with applicable procurement guidelines.

##### **1.2 Scope of Work**

###### **1.2.1 Background**

LAVTA operates the Wheels bus system, which provides fixed-route, Rapid, school route, commuter express, and Dial-A-Ride paratransit service to ADA eligible citizens in the cities of Dublin, Livermore, and Pleasanton, and adjacent unincorporated areas of eastern Alameda County.

Funding for the system is provided by federal, state, and local sources. The seven-member LAVTA Board of Directors is responsible for the development of policy and oversight of LAVTA’s services and programs.

LAVTA’s Executive Director oversees the operation of the transit system in accordance with the policy direction prescribed by the Board of Directors and is responsible for the overall administration of the fixed-route and paratransit system. At present, the Executive Director is supported by a staff of fourteen (14) employees. Contractors and consultants are retained as needed to provide specialized planning, marketing, and technical assistance.

It is expected that LAVTA will budget \$250,000 in the first year and \$75,000 in each of the following two years over the next three years for on-call bus shelter installation, removal, and related services and therefore, the contract will be for a sum not-to-exceed Four Hundred Thousand dollars (\$400,000). During this period, LAVTA may also procure bus shelter-related projects separate from and in addition to this Request for Proposals that have distinct scope and delivery requirements. Respondents to this Request for Proposals are not precluded from responding to other procurement opportunities LAVTA may make available during the contract period, provided appropriate staffing and response times can be maintained for services under this Contract. Retention of on-call bus shelter installation, removal, and related services is not a guarantee of work unless a task order is issued or other work prosecuted as described further in Sections 1.2.2 and 1.2.3.

Bus shelter installation, removal, and relocation services will be provided on an as-needed basis, through a Task Order on-call process. The Task Order process will consist of LAVTA contacting the Contractor and requesting labor, equipment, and/or services related to an individual project. The Contractor will then prepare a detailed scope and budget proposal for each individual Task Order based on the prices set forth in the Contractor's price proposal submitted pursuant to this RFP. The Task Orders will be agreed upon in advance between LAVTA and the Contractor.

### 1.2.2 Task Order Process

Task Orders will be initiated in accordance with the following procedure as they relate to work under Sections A, B, and C, as listed in Appendix A:

- LAVTA's Project Manager will issue a Task Order Proposal Request to Contractor, which will define the Scope of Work, deliverables, and required schedule.
- Task Orders will be issued on a negotiated not-to-exceed price based on the individual project requirements and the unit prices set forth in the Contractor's price proposal submitted pursuant to this RFP. The Task Orders cannot exceed in aggregate the total contract not-to-exceed amount of \$400,000.
- Contractor will submit its Task Order Proposal to LAVTA's Project Manager within five (5) days of receipt of the Task Order Proposal Request. The Task Order Proposal shall include the Contractor's understanding of the Scope of Work, deliverables and schedule, and will include a cost proposal. Also included will be the names of the Contractor (and subcontractor) personnel proposed under the Task Order.
- LAVTA will review the Task Order Proposal for compliance with contractual requirements and will conduct a technical evaluation to ensure the Task Order Proposal is complete and is consistent with the Scope of Work and that all costs proposed are appropriate.
- If required, LAVTA will conduct negotiations to address exceptions and costs identified in the Task Order Proposal. After negotiations, Contractor will submit a revised Task Order Proposal within five (5) days.
- LAVTA will issue the Task Order within five (5) days after receipt of an accepted Task Order Proposal.
- Work shall be performed under the direction of LAVTA's staff representative identified in the Task Order.

### 1.2.3 General

The Contractor shall function with overall guidance from LAVTA staff, but will manage and control the day-to-day work directive activities and deliverables.

In addition to the Task Order Process described above, the Contractor shall be on-call to undertake maintenance-related repairs, parts installation, and removal of LAVTA's passenger amenities as listed and identified in Section D of Appendix A, "Proposal Forms for On Call Bus Shelter Installation, Removal, and Related Services." The contractor shall be notified by phone regarding a shelter maintenance job. A response from the contractor shall be required within 24 hours of the initial call. The required response time and duration of any job shall be negotiated between the Contractor and LAVTA staff overseeing the job as described further in Appendix A. Specific services may include but not be limited to the following:

- Install aluminum plexiglass shelter
- Install perforated metal shelter
- Install steel and glass shelter
- Attach a bus stop sign to an existing fixture
- Install bus stop sign with pole in concrete
- Install bus stop sign with pole in dirt
- Install metal trash receptacle in concrete
- Install metal/wood bench in concrete
- Install display case on glass
- Install display case on perforated metal
- Install display case on plexiglass
- Install bike rack (hoop style) in concrete (bolted on)
- Install solar light kit on a shelter
- Remove and replace broken/damaged glass panel from shelter
- Remove and replace broken/damaged plexiglass panel from shelter
- Remove and replace broken/damaged perforated steel panel from shelter
- Install graffiti guard on a glass panel
- Remove and replace graffiti guard on a glass panel
- Relocate a metal trash receptacle
- Remove and replace a damaged metal trash receptacle
- Remove and replace damaged metal top or door on trash receptacles
- Remove and replace damaged metal/wood benches
- Remove and replace damaged wood bench
- Remove and replace damaged display case on glass shelter
- Remove and replace damaged display case on perforated steel shelter
- Remove and replace damaged plastic roof on aluminum shelters
- Remove and replace damaged roof (peak style) on steel shelters
- Remove a bus stop sign from concrete
- Remove a bus stop sign from dirt
- Remove and install logo on glass bus shelters

### **1.3 Contract Period**

The initial contract period is for one (1) year from the effective date, with two (2) one-year options, to be exercised solely at LAVTA's discretion.

## **2 ADDITIONAL REQUIREMENTS**

### **2.1 Confidentiality**

The California Public Records Act (California Government Code Sections 6250 et seq.) mandates public access to government records. Therefore, unless the information is exempt from disclosure by law, the content of any request for explanation, exception or substitution, response to these specifications, protest or any other written communication between Authority and the proposer shall be available to the public.

If the proposer believes any communication contains trade secrets or other proprietary information that the proposer believes would cause substantial injury to the proposer's competitive position if disclosed, the proposer shall request that Authority withhold from disclosure the proprietary information by marking each page containing such proprietary information as confidential. The proposer may not designate its entire proposal or bid as confidential. Additionally, proposer may not designate its cost proposal or any required bid forms or certifications as confidential.

If proposer requests that Authority withhold from disclosure information identified as confidential, and Authority complies with the proposer's request, proposer shall assume all responsibility for any challenges resulting from the non-disclosure, indemnify and hold harmless Authority from and against all damages (including but not limited to attorneys' fees that may be awarded to the party requesting the proposer information), and pay any and all costs and expenses related to the withholding of proposer information.

Proposer shall not make a claim, sue or maintain any legal action against Authority or its directors, officers, employees or agents in connection with the withholding from disclosure of proposer information.

If proposer does not request that Authority withhold from disclosure information identified as confidential, Authority shall have no obligation to withhold the information from disclosure and may release the information sought without any liability to Authority.

### **2.2 Conflict of Interest**

Proposer represents and warrants that it presently has no interest and agrees that it will not acquire any interest which would present a conflict of interest under California Government Code §§ 1090 et seq. or §§ 87100 et seq. during the performance of services under the Agreement. Proposer shall promptly disclose any actual or potential conflict of interest to Authority as soon as proposer becomes aware of such conflict. Proposer further covenants that it will not knowingly employ any person having such an interest in the performance of the Agreement. Violation of this provision may result in the Agreement being deemed void and unenforceable.

No member, officer or employee of the Authority or of any of its member jurisdictions during his/her tenure of office, or for one year thereafter, shall have any interest, direct or indirect, in this contract or the proceeds therefrom.



SECTION III

PROPOSAL CONTENT

**SECTION III – Proposal Content**

**On-Call Bus Shelter Installation, Removal and Related Services**

**Table of Contents**

<b>1</b>	<b>FORMAT.....</b>	<b>III-1</b>
<b>2</b>	<b>COVER FORM.....</b>	<b>III-1</b>
<b>3</b>	<b>EVIDENCE OF ABILITY TO PROVIDE INSURANCE .....</b>	<b>III-2</b>
<b>4</b>	<b>PROPOSER’S QUALIFICATIONS, EXPERIENCE AND REFERENCES .....</b>	<b>III-2</b>
<b>5</b>	<b>TECHNICAL PROPOSAL .....</b>	<b>III-3</b>
<b>6</b>	<b>PRICE PROPOSAL .....</b>	<b>III-3</b>
<b>7</b>	<b>SUPPORTING DOCUMENTATION (NO PAGE LIMIT) .....</b>	<b>III-3</b>
<b>8</b>	<b>COMPLETED REQUIRED FORMS (PROVIDED IN APPENDIX A) .....</b>	<b>III-4</b>

## **SECTION III – Proposal Content**

### **On-Call Bus Shelter Installation, Removal and Related Services**

#### **1 FORMAT**

The intent of this RFP is to encourage responses that clearly communicate the proposer's understanding of the scope of work and the proposer's proposed approach to meet LAVTA's requirement for on-call bus shelter installation, removal and related services.

Proposals should be limited to specific discussion of the elements outlined in this RFP. Responders are encouraged to avoid submissions that are poorly organized or in which important information is obscured by unnecessary promotional material. Short, succinct, and clear submittals are less likely to be marked down due to uncertainty as to meaning or misinterpretation. The Evaluation Committee will assume the most unfavorable interpretation when information is unclear, ambiguous, or missing. Responders are encouraged to submit proposals that best address the evaluation criteria outlined in Section IV, Evaluation and Award, subsection 1.1.

The organization of the proposal should follow the general outline below. The Technical Proposal section should not exceed 10 pages excluding any appendices.

Respondent's proposal shall include the following items in the following sequence:

#### **2 COVER FORM**

The signed cover form, provided in Appendix A, contains the following:

- a) Date submitted and complete name and address of person who will receive correspondence and who is authorized to make decisions or represent the Proposer and contractually bind the firm. This person shall also sign the Price Proposal Form. Identification shall include legal name of company, corporate address, telephone and fax number and contact person during period of proposal evaluation.
- b) An understanding of the conditions under which the proposal is offered.
- c) Acknowledgement of receipt of all RFP addenda, if any. A statement to the effect that the proposal shall remain valid for a period of not less than one hundred twenty (120) days from the date of submittal.
- d) An understanding that LAVTA reserves the right to reject any or all Proposals or to waive any informality or technicality in any proposal in the interest of LAVTA.
- e) A statement that Proposer is prepared to sign the Sample Agreement without alterations or exceptions or whether it is requesting modifications to the

Sample Agreement and/or any requirements of this RFP. Proposers shall not just attach their own sample agreements as exceptions to LAVTA's Sample Agreement, but instead must include interlineated exceptions to LAVTA's Sample Agreement.

- f) A statement confirming the commitment of adequate resources to meet LAVTA's quality and schedule expectations.
- g) Signature of a person authorized to bind Proposer to the terms of the proposal.

### **3 EVIDENCE OF ABILITY TO PROVIDE INSURANCE**

Provide evidence in the form of a certificate of insurance or letter from Proposer's broker/agent that verifies the firm is able to meet the minimum insurance requirements as detailed in Section II – Scope of Work, subsection 2.1 including, workers' compensation insurance, commercial general liability insurance, and automobile liability insurance.

### **4 PROPOSER'S QUALIFICATIONS, EXPERIENCE AND REFERENCES**

The following information shall be included:

- a) A brief description of the Proposer's qualifications for performing bus shelter installation, removal, and related services, including the organization, size and years in business. This should also include the nature and scope of the firm's experience representing governmental agencies.
- b) Experience – This section should contain a concise description of the proposer's background and experience in bus shelter installation, removal, and related services for transit or other public agencies, said services similar to those outlined in the Scope of Work, listing at least three agencies within the last three years (not including LAVTA). The information submitted should include:
  - Name, address, and telephone number of the responsible official of the organization
  - Reference Agency Website links
  - Cost of the contract
  - Dates services encompass
  - Services provided
  - The status of the contract
- c) Evidence of appropriate licensure to perform the work – this section should include Proposer's Contractor's License Number and the expiration date for such license. Proposers must provide evidence they and all of their subcontractors are registered with the Department of Industrial Relation (DIR). In addition, Proposers will be required to obtain any necessary

business permits as required by the cities of Dublin, Pleasanton, and Livermore.

- d) Financial stability and history of the Proposer - Provide a statement of your firm's financial strength, stability, capacity, and resources. Company official reports and other similar materials (balance sheet and income statements, with 3-year summary history) should be provided. Provide information about the history of the firm, demonstrating viability of the firm.
- Identify any past (within last 3 years) or pending litigation against the Proposer alleging failure to perform in accordance with contractual obligations, and describe present status. If there is no such litigation, this must be explicitly stated.
  - List any projects, which have resulted in time extensions and/or the assessment of liquidated damages against the firm during the last five (5) years.
  - Disclosure of potential conflicts of interest with other clients of the firm.

## **5 TECHNICAL PROPOSAL**

The following shall be included as a description of the proposed services to be provided by the Proposer under this contract:

- a) A complete staffing plan that addresses the Scope of Work as defined in this RFP.
- b) Conformance to the terms of the requirements of the RFP – The Proposer should describe if they can meet all the requirements of the RFP. Any deviation with the RFP requirements should be clearly identified and described. Failure to specify any exceptions or objection to the requirements, and terms and conditions of this RFP will constitute acceptance of LAVTA's requirements.

## **6 PRICE PROPOSAL**

The Proposer shall use the Price Proposal Form provided in Appendix A. The price proposal shall include everything necessary for the completion of and fulfillment of the contract including, but not limited to, materials, equipment, and all management, superintendence, labor and services and all applicable federal, state, and local taxes.

## **7 SUPPORTING DOCUMENTATION (NO PAGE LIMIT)**

Proposals may include other material that may assist in evaluating the Proposal. Supporting documentation should be relevant and brief.

## 8 COMPLETED REQUIRED FORMS (PROVIDED IN APPENDIX A)

- Proposal Cover Form
- Price Proposal
- Certification Regarding Worker Compensation
- Fair Employment Practice Certification
- Certification Concerning Control of Employees

Respondent is expected to examine this RFP carefully, understand the terms and conditions for providing the materials, labor, and services herein and respond completely. **FAILURE TO COMPLETE AND PROVIDE ANY OF THE ABOVE ITEMS MAY RESULT IN THE RESPONDENT'S PROPOSAL BEING DEEMED NON-RESPONSIVE AND THEREFORE DISQUALIFIED FROM CONSIDERATION.**

SECTION IV  
EVALUATION AND AWARD

**SECTION IV – Evaluation and Award**

**On-Call Bus Shelter Installation, Removal and Related Services**

**Table of Contents**

**1 EVALUATION CRITERIA ..... IV-1**  
**2 EVALUATION PROCEDURE ..... IV-1**  
**3 AWARD ..... IV-2**  
**4 NOTIFICATION OF AWARD ..... IV-2**



## SECTION IV – Evaluation and Award

### On-Call Bus Shelter Installation, Removal and Related Services

#### 1 EVALUATION CRITERIA

The Authority will evaluate the Proposals received based on the following criteria:

Criteria	Scoring
Complete and thorough conformance with the terms and requirements of this RFP (In your submittal, state if you have any exceptions to the requirements.)	Pass/Fail
<b>General Qualifications:</b> <ul style="list-style-type: none"><li>• Qualifications and experience of staff</li><li>• Proper insurance coverage and licensure</li><li>• Financial ability of the firm to provide services</li></ul>	10
<b>Understanding the Scope of Work:</b> <ul style="list-style-type: none"><li>• Proposed program</li><li>• Detailed list of services</li><li>• Ability to provide services in a timely manner</li></ul>	20
<b>Price:</b> <ul style="list-style-type: none"><li>• Range of work types and services offered</li><li>• Evaluation of firm's fee schedule</li></ul>	60
<b>References:</b> <ul style="list-style-type: none"><li>• Current contract work experience</li><li>• References from current clients, including transit agencies</li></ul>	10
<b>Total Points</b>	<b>100 points</b>

#### 2 EVALUATION PROCEDURE

To be considered for evaluation, all proposals must be responsive to this Request for Proposals with respect to required submissions and must be compliant with all provisions as documented. LAVTA may reject as nonresponsive any proposal not meeting the requirements of this RFP.

An Evaluation Committee shall be comprised of LAVTA staff, and may include outside personnel. The Committee members will evaluate the written proposals using the criteria identified in Section 1 above.

Firms submitting a proposal in response to this RFP may be required to give a demonstration and presentation of their proposal to LAVTA. This presentation may provide an opportunity for the firms to clarify or elaborate on the proposal but will in no way change the original submission.

Engagement staff shall be present at the oral presentation. LAVTA's request for an oral presentation shall not constitute acceptance of a proposal.

After evaluating proposals based upon the criteria above, the Evaluation Committee will develop a list of top-ranked proposals within a competitive range, based upon the totals of each Committee members' score for each proposal. At this time, proposers may be asked to submit a Revised Proposal. In a request for Revised Proposals, firms may be asked to provide additional information, confirm or clarify issues, and submit a final price offer. A deadline for submission will be stipulated. LAVTA may, in its sole discretion, choose not to require a Revised Proposal, so proposers should submit their best proposal in the initial response.

### **3 AWARD**

The Authority may negotiate contract terms with the selected Proposer prior to award, and expressly reserves the right to negotiate with several Proposers simultaneously and, thereafter, to award a contract to the Proposer offering the most favorable terms to the Authority. LAVTA reserves the right to determine the best value to the Authority through this competitive process using highest-weighted-score analysis technique.

Negotiations may or may not be conducted with Proposers; therefore, the proposal submitted should contain Proposer's most favorable terms and conditions, since the selection and award may be made without discussion with any Proposer.

### **4 NOTIFICATION OF AWARD**

Proposers who submit a proposal in response to this RFP shall be notified by mail regarding LAVTA's intent to award the contract.

**PROPOSAL COVER FORM**  
**For**  
**On-Call Bus Shelter Installation, Removal and Related Services**  
**RFP # 2017-18**

Livermore Amador Valley Transit Authority (LAVTA)  
Livermore, CA

DATE SUBMITTED:

NAME OF INDIVIDUAL SUBMITTING PROPOSAL:

CONTACT PERSON:

NAME UNDER WHICH BUSINESS IS CONDUCTED:

STREET ADDRESS:

MAILING ADDRESS, IF DIFFERENT:

TELEPHONE:

FAX:

BUSINESS LICENSE NUMBER:

CONDITIONS:

1. The undersigned understands that he/she will be bound by the Proposal as expressed by these forms if an award is made by LAVTA. The Contract will be in accordance with this Proposal.
2. The Request for Proposals, Required Forms, and Addenda, if any, are made a part of this Proposal.
3. The undersigned understands that any clarification made to the Proposal Form or any new and different conditions or information submitted in or with the Proposal Form, other than that requested, may render the Proposer unresponsive.

4. The undersigned acknowledges the receipt of the following Addenda:

---

---

---

---

5. The undersigned understands that all proposals shall remain in effect for one hundred twenty (120) days from the date of the submittal.
6. The undersigned understands that LAVTA reserves the right to reject any or all Proposals or to waive any informality or technicality in any proposal in the interest of LAVTA.
7. The undersigned certifies that the Proposal includes all costs for labor, materials, taxes, insurance, overhead, profits, and all other costs necessary to perform the work in accordance with the Contract Documents.
8. The undersigned will submit five (5) sets of their proposal package. The five sets of the proposal package shall be placed in a sealed box (marked "On-Call Bus Shelter Installation, Removal, and Related Services Proposal, RFP 2017-18"). The five sets of a proposer's proposal must be submitted as follows:

One original proposal with required signatures in ink by an officer of the proposer with the authority to bind the proposer to the terms of the RFP submitted in a separate securely sealed envelope marked as follows:

ORIGINAL: On-Call Bus Shelter Installation, Removal and Related Services

Proposers are warned against making erasures or alterations of any kind without initialing each and every change.

Four sets of copies of the proposal submitted in a separate securely sealed envelope marked as follows:

COPIES: On-Call Bus Shelter Installation, Removal and Related Services

The sealed package shall, prior to 2:00 pm Pacific Time on December 20, 2017, be delivered to:

Jennifer Yeaman  
Project Manager  
Livermore Amador Valley Transit Authority  
1362 Rutan Court, Suite 100  
Livermore, CA 94551

9. The undersigned is prepared to sign the Sample Agreement without alterations or exceptions or if it is requesting modifications to the Sample Agreement and/or any requirements of this RFP, shall include such requested modifications in its proposal.

10. The undersigned confirms the commitment of adequate resources to meet LAVTA's quality and schedule expectations.

SIGNED:

The undersigned certify that we sign this Proposal Form with full and proper authorization to do so.

\_\_\_\_\_  
Signature, Printed Name, and Title

\_\_\_\_\_  
Signature, Printed Name, and Title

**IF CORPORATION:**

This Corporation is incorporated under the laws of the State of:

\_\_\_\_\_

\*If Consultant is a corporation, two corporate officers must sign on behalf of the corporation as follows: (1) Chairman of the Board, President, or Vice President; and (2) Secretary, Assistant Secretary, Chief Financial Officer, or Assistant Financial Officer. In the alternative, this Contract may be executed by a single officer or a person other than an officer provided that evidence satisfactory to LAVTA is provided, demonstrating that such individual is authorized to bind the corporation (e.g., a copy of a certified resolution from the corporation's board or a copy of the corporation's by laws).

## Price Proposal

### Section A: Bus Shelter Removal and Disposal (see Appendix B-1 for details)

Item #	Description	Est. Qty for 1-Yr Period	Unit Price	Extended Price
A.1	Remove and dispose of 15 perforated metal shelters and associated amenities and 1 aluminum plexiglass shelter	16	\$	\$
<b>SUBTOTAL SECTION A</b>				<b>\$</b>

### Section B: Bus Shelter Installation (see Appendix B-2 for details)

Item #	Description	Est. Qty for 1-Yr Period	Unit Price	Extended Price
B.1	Install Brasco flat-roof shelter and amenities (hardware included) with solar lighting kit	10	\$	\$
<b>SUBTOTAL SECTION B</b>				<b>\$</b>

### Section C: Bus Shelter Relocation (see Appendix B-3 for details)

Item #	Description	Est. Qty for 1-Yr Period	Unit Price	Extended Price
C.1	Remove aluminum plexiglass shelters in Pleasanton and relocate to LAVTA's Atlantis maintenance facility	4	\$	\$
C.2	Remove aluminum plexiglass shelters in Dublin and relocate to LAVTA's Atlantis maintenance facility.	1	\$	\$
C.3	Remove Metro shelters in Livermore, relocate in Livermore, and install solar light kits.	3	\$	\$
C.5	Remove steel and glass Rapid-style shelters in central Dublin with amenities and relocate to East Dublin.	2	\$	\$
<b>SUBTOTAL SECTION C</b>				<b>\$</b>

**Section D: Related Services (see Appendix B- 4 for details)**

Item #	Description	Est. Qty for 1-Yr Period	Unit Price	Extended Price
D.1	Install aluminum plexiglass shelter	2	\$	\$
D.2	Install steel perforated metal shelter	2	\$	\$
D.3	Install steel glass shelter	7	\$	\$
D.4	Attach a bus stop sign to an existing fixture	10	\$	\$
D.5	Install bus stop sign with pole in existing concrete	5	\$	\$
D.6	Install bus stop sign with pole in dirt with concrete footing	5	\$	\$
D.7	Install metal trash receptacle in concrete	15	\$	\$
D.8	Install metal/wood bench in concrete	30	\$	\$
D.9	Install display case on glass	20	\$	\$
D.10	Install display case on perforated metal	1	\$	\$
D.11	Install display case on plexiglass	1	\$	\$
D.12	Install bike rack (hoop style) in concrete	14	\$	\$
D.13	Install solar light kit on a shelter	5	\$	\$
D.14	Remove and replace broken/damaged glass panel from shelter	15	\$	\$
D.15	Remove and replace broken/damaged plexiglass panel from shelter	10	\$	\$
D.16	Remove and replace broken/damaged perforated steel panel from shelter	2	\$	\$
D.17	Install graffiti guard on a glass panel	100	\$	\$
D.18	Remove and replace graffiti guard on a glass panel	50	\$	\$
D.19	Relocate a metal trash receptacle	4	\$	\$
D.20	Remove and replace a damaged metal trash receptacle	4	\$	\$
D.21	Remove and replace damaged metal top or door on trash receptacles	2	\$	\$
D.22	Remove and replace damaged metal/wood benches	2	\$	\$
D.23	Remove and replace damaged bench	2	\$	\$
D.24	Remove a bike rack bolted to concrete	5	\$	\$
D.25	Remove and replace damaged display case on glass shelter <i>(note: requires removal of glass panel and minimum 24 hours' curing time prior to reinstallation)</i>	5	\$	\$
D.26	Remove and replace damaged display case on perforated steel shelter	2	\$	\$
D.27	Remove and replace damaged plastic roof on aluminum shelters	2	\$	\$

D.28	Remove a bus stop sign from concrete	2	\$	\$
D.29	Remove logo on glass bus shelters	2	\$	\$
D.30	Install logo on glass bus shelters	50	\$	\$
D.31	Prepare and submit written inventory of stored materials (every 3 months)	LS	\$	\$
D.32	Regular hourly rate for non-contemplated work (rate per hour)	LS	\$	\$
D.33	Overtime hourly labor rate for non-contemplated work (rate per hour)	LS	\$	\$
D.34	Weekend/Holiday hourly labor rate for non-contemplated work (rate per hour)	LS	\$	\$
D.35	After-hour/emergency labor rate for non-contemplated work (rate per hour; requires 2-hour response time)	LS	\$	\$
<b>SUBTOTAL SECTION D</b>				<b>\$</b>
<b>GRAND TOTAL PRICE ESTIMATE (SECTIONS A THROUGH D)</b>				<b>\$</b>

SIGNED: The undersigned certify that we sign this Price Proposal Form with full and proper authorization to do so.

\_\_\_\_\_

Company Name

\_\_\_\_\_

Signature, Printed Name, and Title

\_\_\_\_\_

Signature, Printed Name, and Title

\*If Consultant is a corporation, two corporate officers must sign on behalf of the corporation as follows: (1) Chairman of the Board, President, or Vice President; and (2) Secretary, Assistant Secretary, Chief Financial Officer, or Assistant Financial Officer. In the alternative, this Contract may be executed by a single officer or a person other than an officer provided that evidence satisfactory to LAVTA is provided, demonstrating that such individual is authorized to bind the corporation (e.g., a copy of a certified resolution from the corporation's board or a copy of the corporation's by laws).



**CERTIFICATION REGARDING WORKER COMPENSATION**

Contract with the LIVERMORE AMADOR VALLEY TRANSIT AUTHORITY, 1362 Rutan Court, Livermore, California 94551, for On Call Bus Shelter Installation, Removal and Related Services.

RFP # 2017-18

Labor Code Section 3700:

"Every employer, except the State, and all political subdivisions or institutions thereof, shall secure the payment of compensation in one or more of the following ways:

- (a) By being insured against liability to pay compensation by one or more insurers, duly authorized to write compensation insurance in this State.
- (b) By securing from the Director of Industrial Relations a certificate of consent to self-insure, which may be given upon furnishing proof satisfactory to the Director of Industrial Relations of ability to self-insure and to pay any compensation that may become due to employees."

I am aware of the provisions of Section 3700 of the Labor Code, which require every employer to be insured against liability for worker's compensation or to undertake self-insurance. In accordance with the provisions of that code, I will comply with such provisions before commencing the performance of the work of this contract.

Dated: \_\_\_\_\_, 201\_\_  
(Proposer)

By \_\_\_\_\_  
\_\_\_\_\_  
(Official Title)

(SEAL)

(Labor Code Section 1861, provides that the above certificate must be signed and filed by the Proposer with the Authority prior to performing any work under this contract.)

## FAIR EMPLOYMENT PRACTICES CERTIFICATION

In connection with the performance of work under this contract, the Proposer agrees as follows:

1. The Proposer will not willfully discriminate against any employee or applicant for employment because of race, color, religious creed, ancestry, national origin, age, sex, physical disability, mental disabilities, marital status, or medical condition as defined in Government Code §12926. The Proposer will take affirmative action to ensure that applicants are employed and that employees are treated during employment without regard to their race, color, religious creed, ancestry, national origin, age, sex, physical disability, mental disability, marital status, or medical condition as defined in Government Code §12926. Such action shall include, but not be limited to, the following: employment; upgrading; demotion or transfer; recruitment or recruitment advertising; layoff or termination; rates of pay or other forms of compensation; and selection for training including apprenticeship. The Proposer agrees to post in conspicuous places, available to employees and applicants for employment, notices setting forth the provisions of this Fair Employment Practices section.

2. The Proposer will send to each labor union or representative of workers with which it has a collective bargaining agreement or other contract or understanding, a notice, advising the said labor union or workers' representative of the Proposer's commitments under this section; and the Proposer shall post copies of the notice in conspicuous places available to employees and applicants for employment.

3. The Proposer will permit access to its records of employment, employment advertisements, application forms, and other pertinent data and records by the Fair Employment Practices Commission, LAVTA, or any other appropriate agency of the State of California designated by LAVTA for the purposes of investigation to ascertain compliance with the Fair Employment Practices section of this contract.

4. A finding of willful violation of the Fair Employment Practices section of this contract or of the Fair Employment Practices Act shall be regarded by LAVTA as a basis for determining the Proposer to be not a "responsible Proposer" as to future contracts for which such Proposer may submit Proposals, for revoking the Proposer's pre-qualification rating, if any, and for refusing to establish, re-establish, or renew a pre-qualification rating for the Proposer.

LAVTA shall deem a finding of willful violation of the Fair Employment Practices Act to have occurred upon receipt of written notice from the Fair Employment Practices Commission that it has investigated and determined that the Proposer has violated the Fair Employment Practices Act and has issued an order under Government Code §12970 or obtained a court order under Government Code §12973.

Upon receipt of such written notice from the Fair Employment Practices Commission, LAVTA shall notify the Proposer that, unless it demonstrates to the satisfaction of LAVTA within a stated period that the violation has been corrected, the Proposer's pre-qualification rating will be revoked.

5. The Proposer agrees that should LAVTA determine that the Proposer has not complied with the Fair Employment Practices section of this contract then, pursuant to Labor Code Sections 1735 and 1775, the Proposer shall, as a penalty to LAVTA, forfeit, for each calendar day, or portion thereof, for each person who was denied employment as a result of such noncompliance, the penalties provided in the labor code for violation of prevailing wage rates. Such monies may be recovered from the Proposer. LAVTA may deduct any such damages from any monies due the Proposer.

6. Nothing contained in this Fair Employment Practices section shall be construed in any manner of fashion so as to prevent LAVTA from pursuing any other remedies that may be available at law.

7. Prior to award of the contract, the Proposer shall certify to LAVTA that it has or will meet the following standards for affirmative compliance, which shall be evaluated in each case by LAVTA:

a. The Proposer shall provide evidence, as required by LAVTA, that it has notified all supervisors, foremen and other personnel officers, in writing, of the content of the anti-discrimination clause and their responsibilities under it.

b. The Proposer shall provide evidence, as required by LAVTA, that it has notified all sources of employee's referral (including unions, employment agencies, advertisements, Employment Development Department) of the content of the anti-discrimination clause.

c. The Proposer shall file a basic compliance report as required by LAVTA. Willfully false statements made in such reports shall be punishable as provided by law. The compliance report shall also spell out the sources of the work force and who has the responsibility for determining whom to hire or whether or not to hire.

d. Personally, or through its representatives, the Proposer shall, through negotiations with the unions with whom it has agreements, attempt to develop an agreement which will:

(1) Spell out responsibilities for nondiscrimination in hiring, referral, upgrading, and training.

(2) Otherwise implement an affirmative anti-discrimination program in terms of the unions' specific areas of skill and geography to the end that qualified minority workers will be available and given an equal opportunity for employment.

e. The Proposer shall notify LAVTA of opposition to the anti-discrimination clause by individuals, firms, or organizations during the period of its pre-qualification.

8. The Proposer will include the provisions of the foregoing Paragraphs 1 through 7 in every first-tier subcontract so that such provisions will be binding upon each sub consultant.

9. Statements and Payrolls. The Proposer shall maintain its records in conformance with the requirements included in the Information to Proposers and the following Special Conditions:

a. The submission by the Proposer of payrolls or copies thereof, is not required. However, each Proposer and sub-contractor shall preserve their weekly payroll records for a period of three (3) years from the date of completion of this contract.

b. The payroll records shall contain the name, address and social security number of each employee, his/her correct classification, rate of pay, daily and weekly number of hours worked, itemized deductions made, and actual wages paid.

c. The Proposer shall make its payroll records available at the project site for inspection by LAVTA and shall permit LAVTA to interview employees during working hours on the job.

The following certification is to be executed by every Proposer and enclosed and forwarded in a sealed envelope containing the Proposal. The person signing the certification shall state his/her address and official capacity.

### Fair Employment Practice Certification

The undersigned, in submitting a Proposal for performing work as specified in the Scope of Work hereby certifies that the Proposer will meet the above standards of affirmative compliance with the Fair Employment Practices Act.

---

PROPOSER

---

SIGNATURE

---

PRINTED NAME OF SIGNER

---

TITLE

---

MAILING ADDRESS

---

CITY

STATE

ZIP CODE

---

TELEPHONE NUMBER

---

DATE

**LIVERMORE AMADOR VALLEY TRANSIT AUTHORITY  
A CERTIFICATION CONCERNING CONTROL OF EMPLOYEES  
OF CONTRACTOR**

The Contractor, by entering into this Agreement with LAVTA to perform or provide work, services or materials to LAVTA, does hereby certify and assure that in performing the services under this Agreement, the Contractor shall act as an independent contractor and shall have full control of the work and Contractor's employees. Contractor and its employees, under no circumstances whatsoever, shall imply or be considered as an agent(s) or employee(s) of LAVTA. Contractor employees, under no circumstances, shall be entitled to part of any pension plan, insurance, bonus, or any similar benefits which LAVTA provides its own employees.

Any infraction of this Certification shall be cause for termination of this agreement.

Authorized Representative of Proposer

\_\_\_\_\_  
Signed

\_\_\_\_\_  
Title

\_\_\_\_\_  
Date

# APPENDIX B-1: BUS SHELTERS AND AMENITIES TO REMOVE



## Livermore Amador Valley Transit Authority

*All locations are in Livermore, CA. Stop locations where replacement shelters are to be installed are noted as such.*

Stop 1: East Stanley Blvd. & Wall St.

---



**Stop 2: First Street & Las Positas Rd. New Metro-style shelter to be installed (see Appendix B-2).**

---







Stop 4: Junction Ave & Chestnut St. New Metro-style shelter to be installed (see Appendix B-2).

---







Stop 7: First Street & Las Positas Rd. New Metro-style shelter to be installed (see Appendix B-2).

---



**Stop 8: Scenic Drive & North Vasco Rd. Replace with Relocated Shelter from Stop #23 (see Appendix B-3).**

---











Stop 12: Vasco Road & Las Positas Road. Replace with Relocated Shelter from Stop #21 (see Appendix B-3).

---











# MAPS OF LIVERMORE SHELTER-REMOVAL LOCATIONS



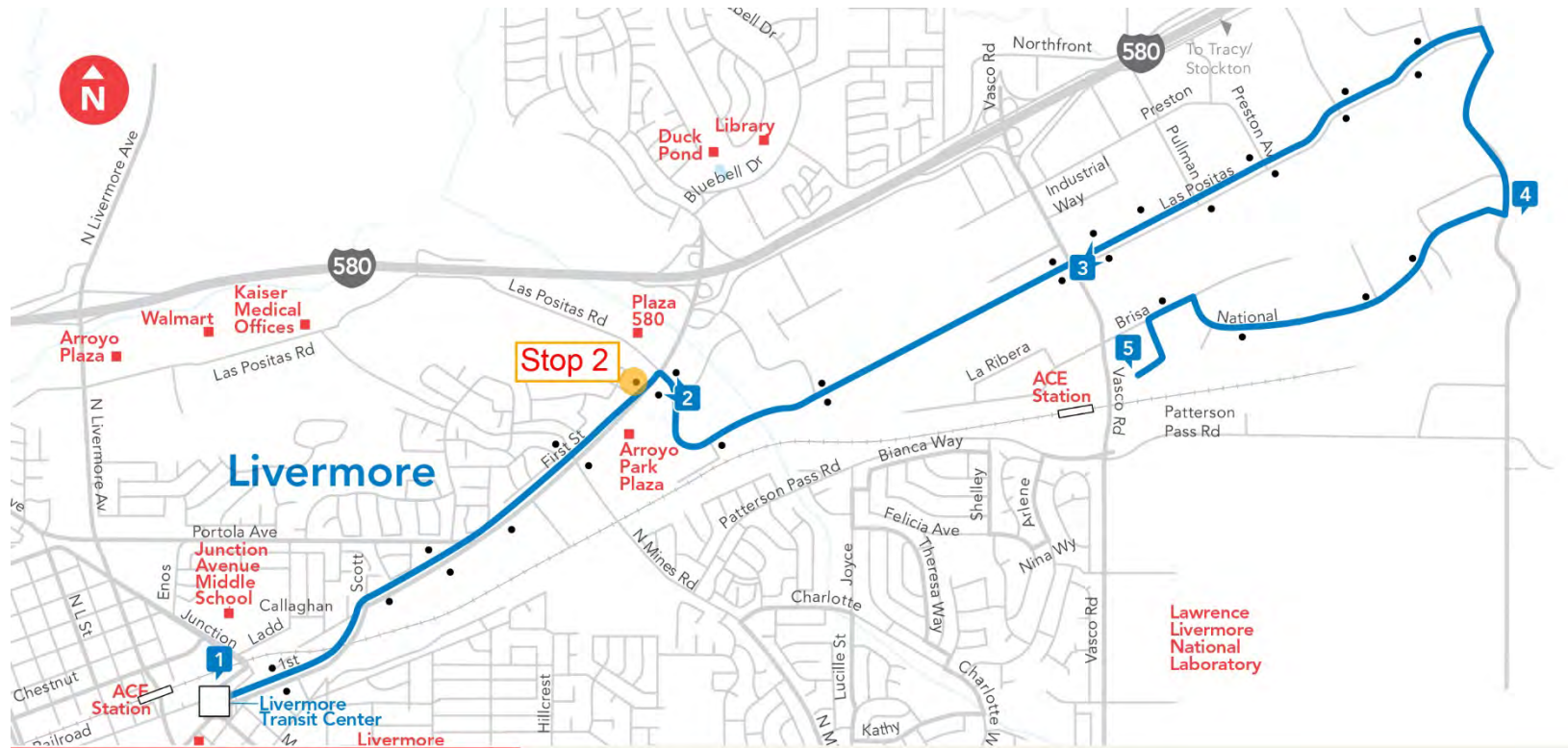





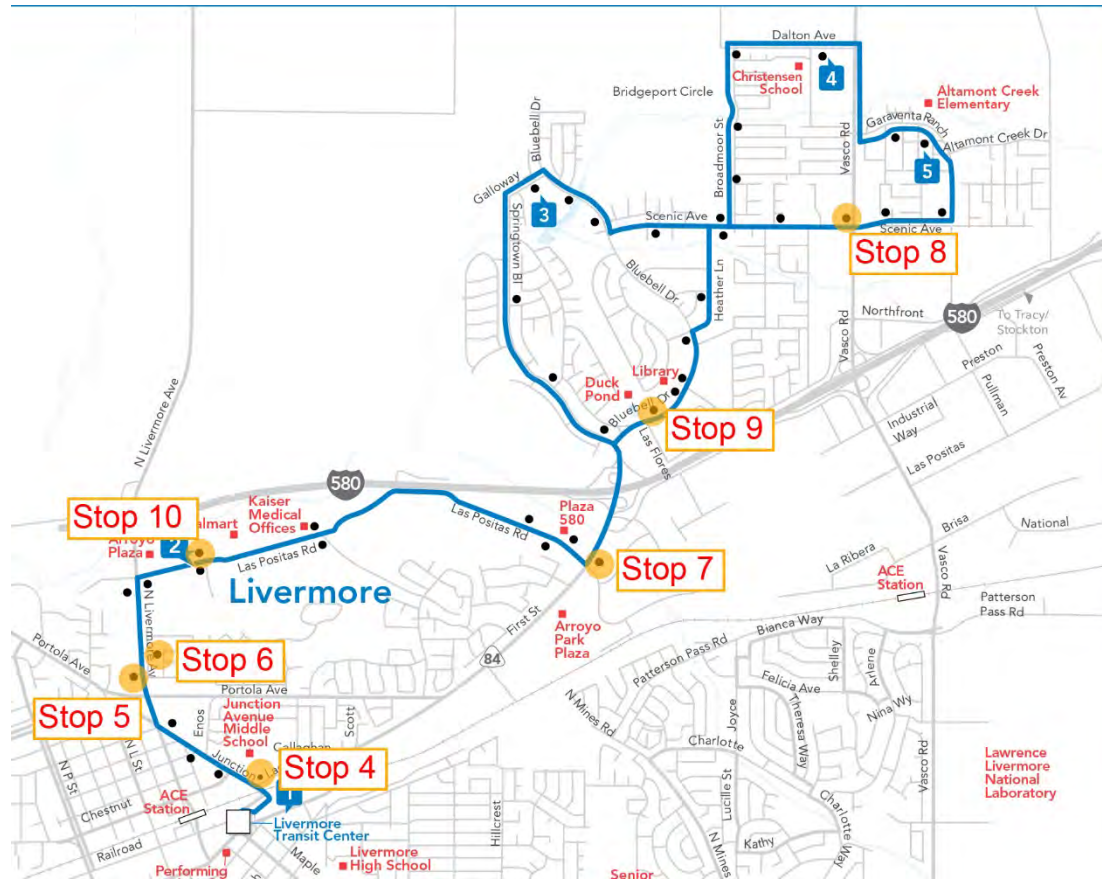

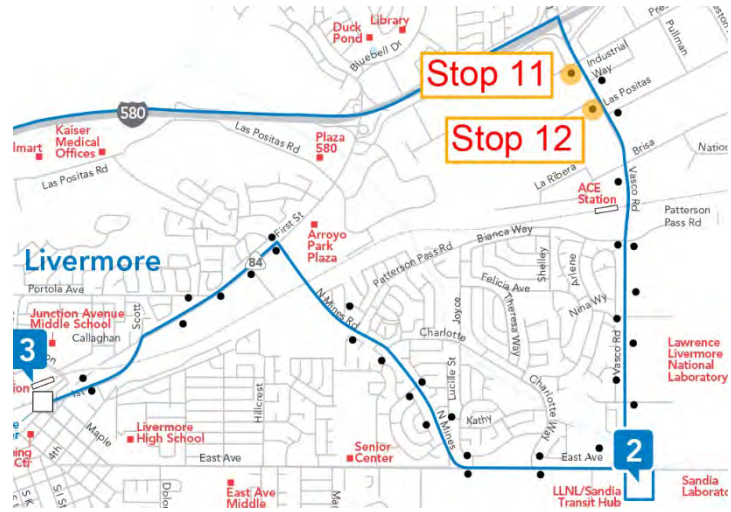

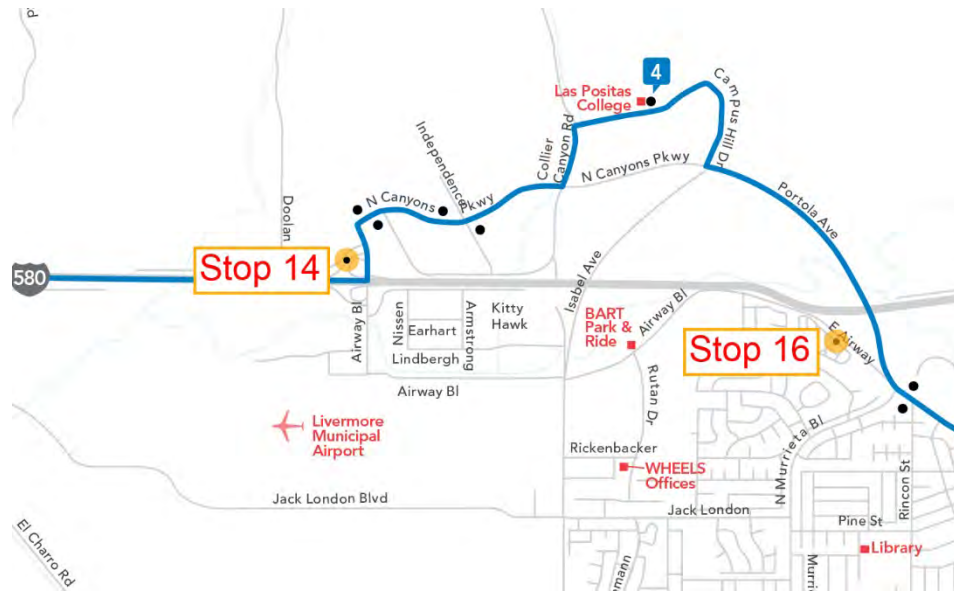

# APPENDIX B-2: TECHNICAL SPECIFICATIONS FOR 10 BUS SHELTERS AND AMENITIES TO INSTALL



Livermore Amador Valley Transit Authority

*All installation locations are in Livermore, CA*

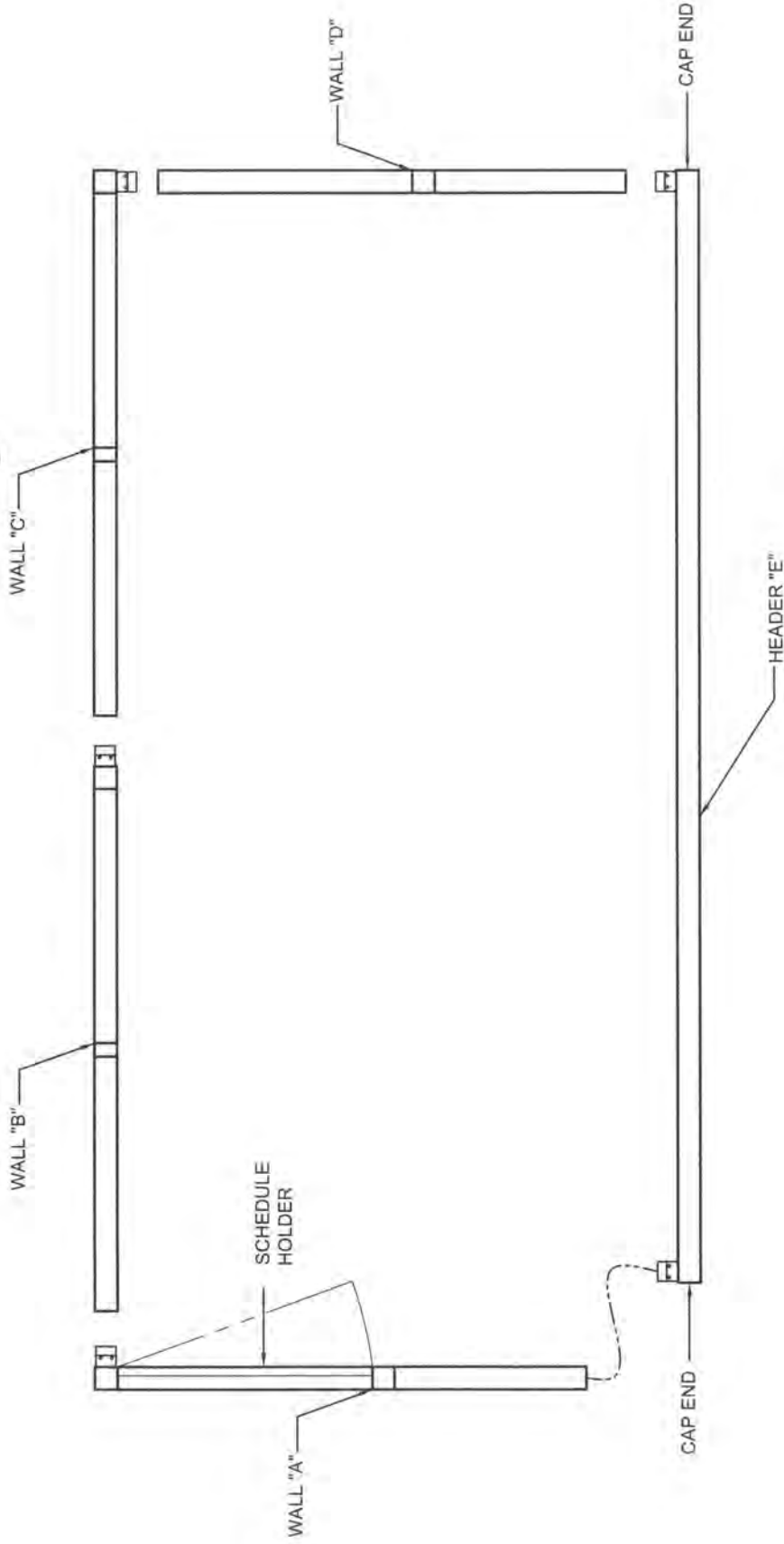

**QUANTITY (10) SHELTERS THUS**

**SPECIFICATIONS:**

- DARK BRONZE ANODIZED ALUMINUM STRUCTURE
- WALL GLAZING BY OTHERS
- SASH AND GASKET FOR 1/2" GLAZING WILL BE PROVIDED
- WHITE FLAT PAN ROOF WITH FASCIA/GUTTER SYSTEM
- 6" PERFORATED CURVELINE BENCH
- 27 5/8" X 24" SCHEDULE HOLDER

**BRASCO INTERNATIONAL, INC.**  
 32400 INDUSTRIAL DRIVE  
 MADISON HEIGHTS, MICHIGAN 48071  
 1-800-893-3665 WWW.BRASCO.COM

THIS DRAWING IS CONFIDENTIAL AND IS FOR THE SOLE USE OF OUR CUSTOMERS AND MAY NOT BE REPRODUCED OR COPIED WITHOUT WRITTEN PERMISSION FROM BRASCO INTERNATIONAL. LEAD TIME BEGINS UPON RECEIPT OF SIGNED APPROVAL.



©

SIGNED: \_\_\_\_\_

DATE: \_\_\_\_\_

ENGINEER:	ZTL
DATE:	5-9-17
CHECKER:	SJT
DATE:	6-16-17
SHEET #:	4993-2

CUSTOMER:	BRASCO INTERNATIONAL
PROJECT:	FLAT PAN STYLE TRANSIT SHELTER
MODEL:	SLIMLINE SERIES - SL512-C
JOB #	4993

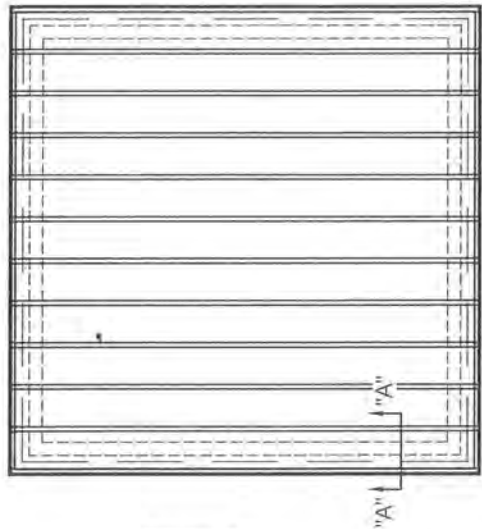

PANS RUN TO REAR OF SHELTER

"A" "A"

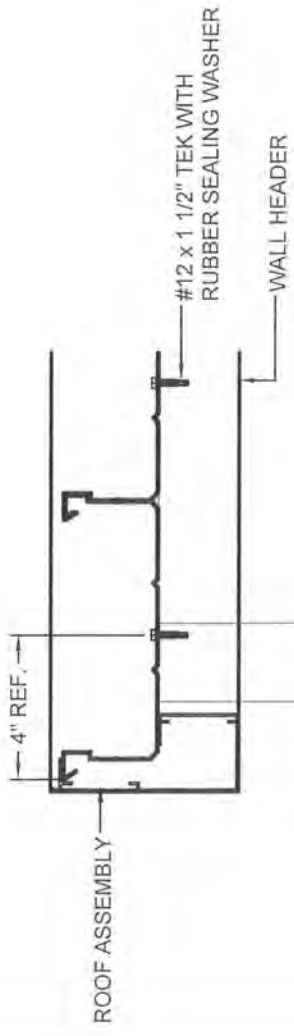

SECTION "A-A"

6) MAKE SURE TOP OF HEADER BEAMS ARE CLEAN AND CLEAR OF DEBRIS. SET THE ROOF MODULE ONTO SHELTER WALL SECTIONS (FIGURE 6). CENTER ROOF IN BOTH DIRECTIONS.

7) SECURE ROOF USING (1) #12 x 1 1/2" S.S. TEK SCREW WITH RUBBER SEALING WASHER IN EACH END OF ROOF PAN (CENTERED). SECURE PANS ALONG THE SIDE LENGTH USING (1) #12 x 1 1/2" S.S. TEK SCREW WITH RUBBER SEALING WASHER APPROX. EVERY 18" ON CENTER.

**BRASCO INTERNATIONAL, INC.**  
 32400 INDUSTRIAL DRIVE  
 MADISON HEIGHTS, MICHIGAN 48071  
 1-800-893-3665 WWW.BRASCO.COM

THIS DRAWING IS CONFIDENTIAL AND IS FOR THE SOLE USE OF OUR CUSTOMERS AND MAY NOT BE REPRODUCED OR COPIED WITHOUT WRITTEN PERMISSION FROM BRASCO INTERNATIONAL. LEAD TIME BEGINS UPON RECEIPT OF SIGNED APPROVAL.

SIGNED: \_\_\_\_\_ DATE: \_\_\_\_\_

CUSTOMER:	INSTALLATION INSTRUCTIONS	ENGINEER:	SJT
PROJECT:	SLIMLINE STYLE TRANSIT SHELTER	DATE:	11-10-11
MODEL:	SLIMLINE SERIES	CHECKER:	BDH
		DATE:	11-18-11
		SHEET #:	3

JOB #



BRASCO INTERNATIONAL, INC.

# INSTALLATION GUIDELINES

Thank you for your order with Brasco International, Inc. Attached to these Guidelines are engineering instructions specific to your order. Please review all pages in full before proceeding with your installation.

### Storage:

- It is important that products stored outside be fully tarped. Wooden crates, cardboard boxes and identifying labels are not weatherproof and will deteriorate in the elements.
- If your order includes solar lighting, be cautious when handling batteries as they are capable of generating hazardous short-circuit currents. Remove all jewelry (bracelets, metal watches, rings) before attempting to handle or disassemble batteries.
- Batteries should be stored indoors at a recommended 68 degrees Fahrenheit for max. shelf life.
- Batteries should be installed no later than 3 months of delivery or battery warranties will be void.

### Cleaning

- Do not use anything abrasive (steel wool, abrasive brushes) to clean any surface. Anodized surfaces are prone to marring from abrasives. Painted surfaces will dull as a result, and glass and plastic may scratch and break down.
- Over cleaning or excessive rubbing can do more harm than good.
- To prevent marring, make sure cleaning sponges, clothes, etc. are free of grit or dirt.
- Strong solvents can cause damage to the finished surfaces of both anodized and powder coated aluminum. Always clean a test surface in an inconspicuous area first.
- Avoid temperature extremes as heat can accelerate chemical reactions and may evaporate water from cleaning solutions. Extremely low temperatures may result in poor cleaning results.
- Solar panels need to be regularly cleaned to ensure maximum performance. Clean as needed with water and a soft cloth or sponge using a mild non-abrasive soap, and rinse well.

### COMMON TOOLS NEEDED FOR INSTALLATION

- |  |  |  |
|--|--|--|
| <input type="checkbox"/> Drill Motor                     | <input type="checkbox"/> Cordless Drill                    | <input type="checkbox"/> Rivet Gun                       |
| <input type="checkbox"/> 1/4" Drill Bit                  | <input type="checkbox"/> Air Compressor                    | <input type="checkbox"/> Tape Measure                    |
| <input type="checkbox"/> #11 Drill Bit                   | <input type="checkbox"/> Steel Hammer                      | <input type="checkbox"/> Torque Wrench                   |
| <input type="checkbox"/> 8" Long 1/2" Masonry Drill Bits | <input type="checkbox"/> Dead Blow Hammer or Mallet        | <input type="checkbox"/> 60" Bar Clamps                  |
| <input type="checkbox"/> 5/8" and 3/4" Socket and Wrench | <input type="checkbox"/> Bubble Level, Line / String Level | <input type="checkbox"/> Generator of Other Power Source |
| <input type="checkbox"/> HD Drill Motor or Hammer Drill  | <input type="checkbox"/> Min. 6ft. Step Ladder             | <input type="checkbox"/> Shop Vac or Broom for Clean Up  |

Brasco International, Inc.  
 32400 Industrial Dr.  
 Waukegan Heights, IL 40071

P (313) 383-0393  
 F (313) 383-0495  
 info@brasco.com

Product information is subject to change without notice.  
 © 2016 Brasco International, Inc.  
 All Rights Reserved.



## Expansion Anchor Guidelines

### Expansion Anchor Installed

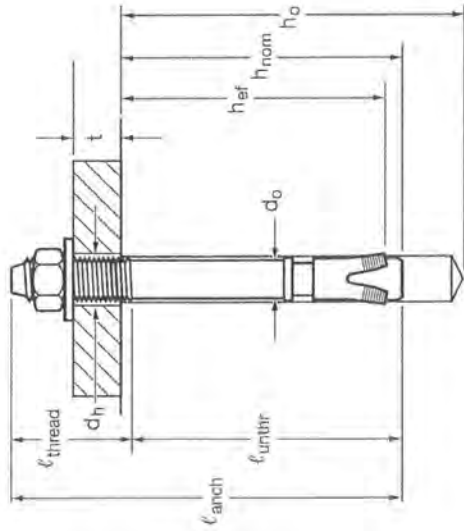

### Expansion Anchor Technical Reference Chart

Setting information	Symbol	Units	Nominal anchor diameter, $d_a$			
			3/8	1/2	5/8	3/4
Nominal bit diameter	$d_{bit}$	in.	3/8	1/2	5/8	3/4
Minimum nominal embedment	$h_{nom}$	in. (mm)	2-5/16 (59)	2-3/8 (60)	3-5/8 (91)	4-7/16 (113)
Effective minimum embedment	$h_{ef}$	in. (mm)	2 (51)	2 (51)	3-1/4 (79)	4 (102)
Min. hole depth	$h_o$	in. (mm)	2-5/8 (67)	2-5/8 (67)	3-3/4 (95)	4-5/8 (117)
Min. thickness of fixture	$t_{min}$	in. (mm)	1/8 (3)	1/8 (3)	n/a	n/a
Max. thickness of fixture	$t_{max}$	in. (mm)	2-1/4 (57)	4 (101)	2-3/4 (70)	4-3/4 (121)
Installation torque	$T_{inst}$	ft-lb (Nm)	25 (34)	40 (54)	60 (81)	110 (149)
Fixture hole diameter	$d_f$	in. (mm)	7/16 (11.1)	9/16 (14.3)	11/16 (17.5)	13/16 (20.6)
Available anchor lengths	$l_{avail}$	in. (mm)	3 (76)	3-3/4 (95)	4-1/2 (114)	5-1/2 (140)
Threaded length including dog point	$l_{thread}$	in. (mm)	7/8 (22)	1-5/8 (41)	2-3/8 (60)	3-3/8 (86)
Unthreaded length	$l_{unthr}$	in. (mm)	2-1/8 (54)	2-1/8 (54)	3-1/4 (83)	4 (102)

1. Minimum thickness of fixture is a concern only when the anchor is installed at the minimum nominal embedment. When KWIK Bolt TZ anchors are installed at this embedment, the anchor threading ends near the surface of the concrete. If the fixture is sufficiently thin, it could be possible to run the nut to the bottom of the threading during application of the installation torque. If fixtures are thin, it is recommended that embedment be increased accordingly.

### Anchoring Expansion Anchors into Concrete

#### Step 1. Prepping the Concrete:

Using anchor boot as a template, mark hole locations and move anchor boot out of the way. Drill a hole the same diameter as the expansion anchor to a minimum depth of 1/2" deeper than the anchor will penetrate to allow debris to fall during installation

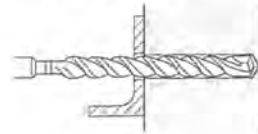

#### Step 2. Prepping the Hole:

Clean debris from holes using a wire brush, vacuum, or compressed air.

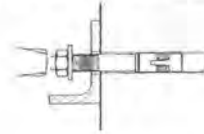

#### Step 3. Anchor Installation:

Replace the anchor boot and align with holes in the concrete. Make sure the nut on the expansion anchor is threaded to the top of the threaded rod to prevent damage to the threads. Insert the expansion anchor through the base plate and into the hole in the concrete. Hit the expansion anchor with sharp blows until the washers are snug against the base plates;

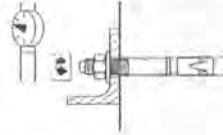

#### Step 4. Securing the Anchor Boot:

Tighten the nut to the recommended installation torque.



Brasco International, Inc.  
32400 Industrial Dr.  
Madison Heights, MI 48071

P (313) 353-0333  
F (313) 353-0499  
info@brasco.com

Product information is subject to change without notice.  
© 2016 Brasco International, Inc.  
All Rights Reserved.

### Standard Brasco Anchoring Guidelines

1. Locating proper column locations is critical. Care must be taken to keep columns plumb and walls square to each other.
2. Shelter should be sloped slightly to the rear for proper drainage. Approximately 1/4 inch slope per ft. from front to rear of shelter is recommended. Columns should be shimmed as necessary.
3. Anchors to be installed in conjunction with manufacturers recommendations only. (See Expansion Anchor technical chart)
4. Anchors need to be installed a minimum of 6 inches from the edge of the concrete pad. See [Brasco's General Concrete Pad Recommendations](#) for reference.

### Anchoring System Overview



### General Concrete Pad Recommendations

**PLEASE NOTE:** These recommendations are to serve as a reference only. Brasco is not liable for concrete installation instructions unless structural concrete calculations are included with an order. Consult your local building codes for specific concrete pad requirements.

**RECOMMENDATION:** Brasco recommends a minimum of 4 inch thick, 3000 PSI concrete pad. The concrete pad should allow a minimum of 6 inches around the shelter perimeter to prevent concrete breakage when anchoring to the pad. Concrete may or may not require additional reinforcement. If concrete calculations are required for installation or permitting purposes, please contact your Brasco account manager for a quote.

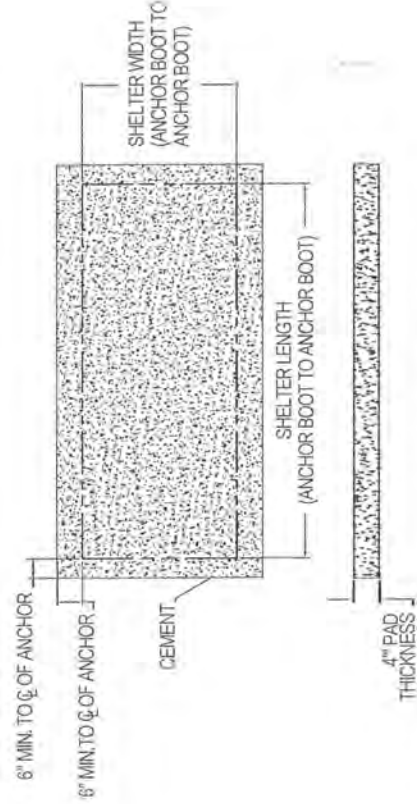

Brasco International, Inc.  
32400 Industrial Dr.  
Madison Heights, MI 48071

P: (313) 350-0323  
F: (313) 358-0488  
www.brasco.com

Product information is subject to change without notice.  
© 2010 Brasco International, Inc.  
All Rights Reserved.

# APPENDIX B-3: BUS SHELTERS AND AMENITIES TO RELOCATE



## Livermore Amador Valley Transit Authority

*Various locations in Dublin, Pleasanton, and Livermore, CA. Destination locations for relocated shelters and amenities are as noted.*









Stop 21: Livermore; Murrieta & Portola; Relocate shelter and bench to Vasco Rd. & Las Positas Rd. in Livermore (see Appendix B-1 Stop #12).

---





**Stop 22: Livermore; Murrieta & Fenton; Repair damaged plexiglass panel and relocate shelter and bench to Vasco Rd. & Industrial Way in Livermore (see Appendix B-1 Stop #11).**

---



Stop 23: Livermore; Holmes & Concannon; Relocate to Scenic Ave. and Vasco Rd. in Livermore (see Appendix B-1 Stop #8).

---









# MAPS OF SHELTERS TO BE RELOCATED









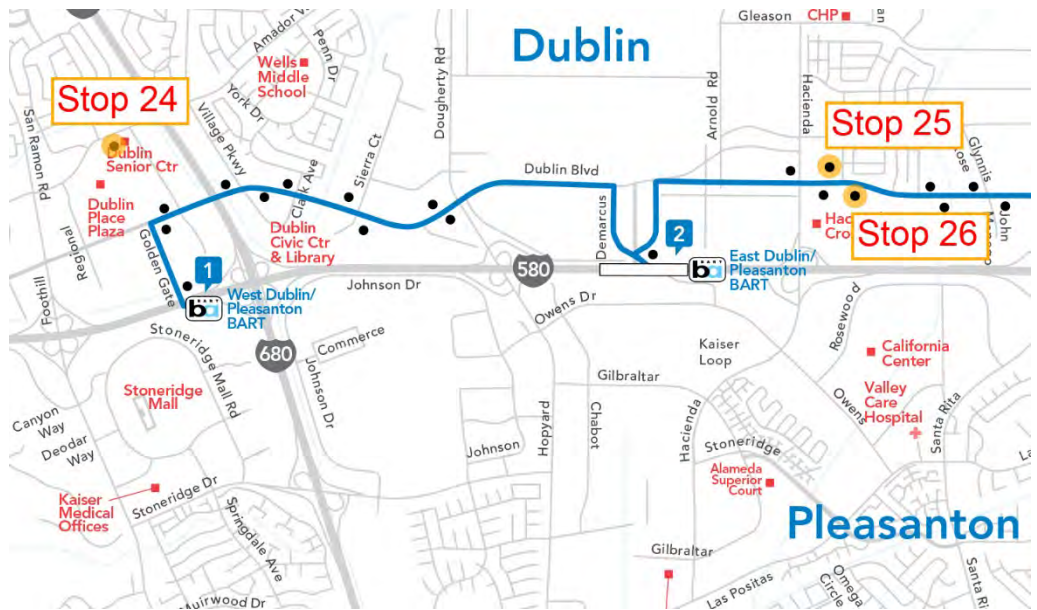



Location of LAVTA's Atlantis Maintenance Facility, 875 Atlantis Court, Livermore, CA 94551

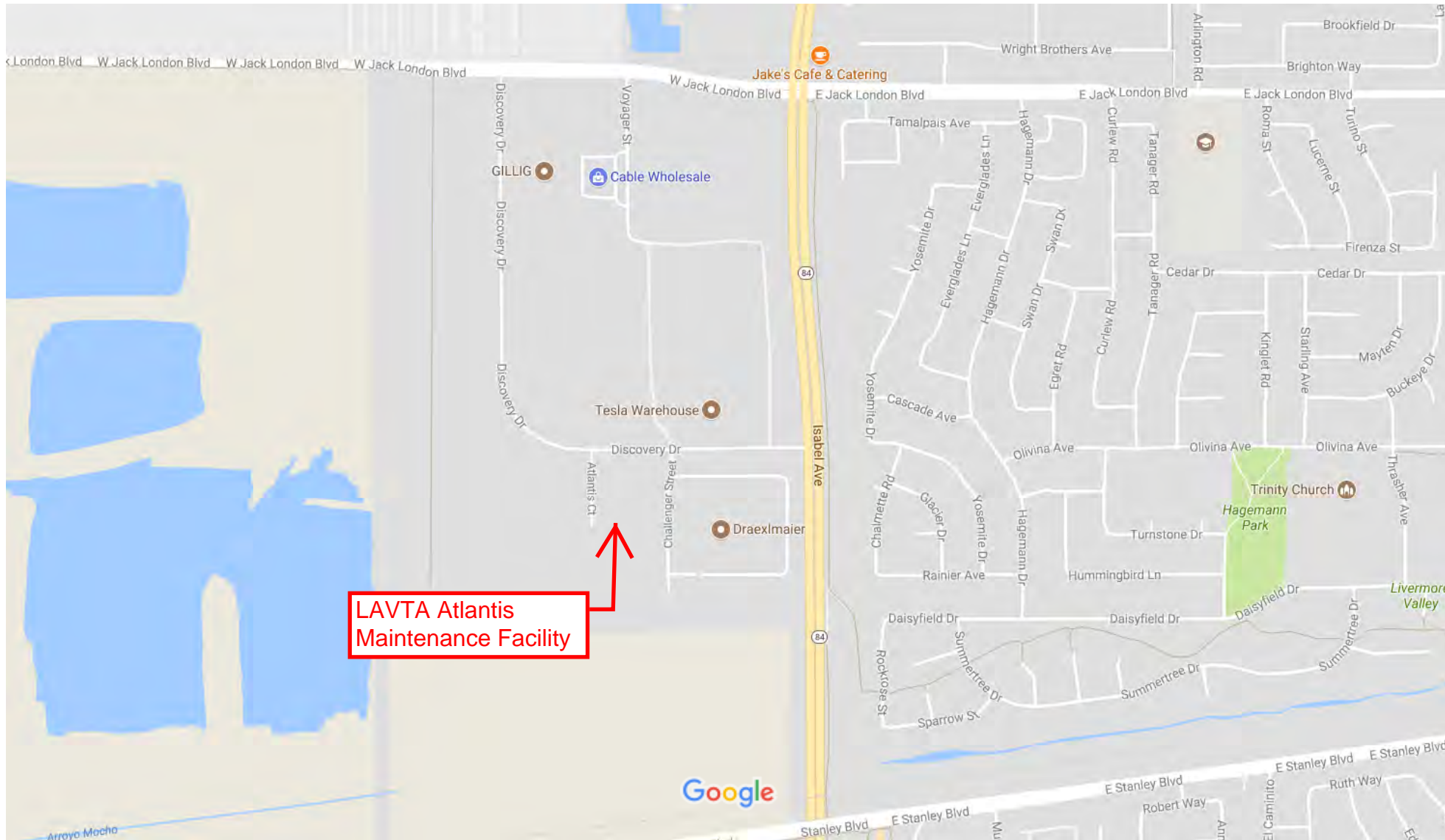

LAVTA Atlantis Maintenance Facility

Map data ©2017 Google 500 ft

# APPENDIX B-4: MISCELLANEOUS SPECIFICATIONS FOR CERTAIN BUS SHELTERS AND AMENITIES



## Livermore Amador Valley Transit Authority

*This is a sample set of specifications for some of LAVTA's shelter equipment and related amenities that may have special installation or maintenance considerations. Other specifications can be provided upon request.*



DURABILITY WITH DISTINCTION

## **INSTALLATION INSTRUCTIONS**

**13' NON- AD BUS STOP SHELTER ELECTRIC  
WITH GLASS END WALL AND SOLAR.**

TOLAR MANUFACTURING COMPANY INC.

TRANSIT SHELTERS | STREET FURNITURE | DISPLAYS & DIRECTORIES | TRANSIT SOLAR LIGHTING  
258 Mariah Circle, Corona, CA USA 92879-1751 | 800-339-6165 | 951-808-0081 | [www.tolarmfg.com](http://www.tolarmfg.com)

### 4.3.5 Kwik Bolt 3 Expansion Anchor

#### 4.3.5.3 Technical Data

Table 1 - Kwik Bolt 3 Specifications<sup>1</sup>

Details		Bolt Size	1/4 (6.4)			3/8 (9.5)			1/2 (12.7)		
$d_{bit}$	nominal bit diameter <sup>2</sup>	in. (mm)	1/4			3/8			1/2		
$h_{min}/h_{nom}/h_{deep}$	depth of embedment	in. (mm)	1-1/8 (29)	2 (51)	3 (76)	1-5/8 (41)	2-1/2 (64)	3-1/2 (89)	2-1/4 (57)	3-1/2 (89)	4-3/4 (121)
$h_o$	minimum/standard/deep hole depth	in. (mm)	1-3/8 (35)	2-1/4 (57)	3-1/4 (83)	2 (51)	2-7/8 (73)	3-7/8 (89)	2-3/4 (70)	4 (102)	5-1/4 (133)
$d_h$	wedge clearance hole in fixture	in. (mm)	5/16 (8)			7/16 (11)			9/16 (14)		
$T_{inst}$ Recommended Installation Torque	Normal weight & Light weight Concrete	Carbon Steel HDG	ft-lb (Nm)			20 (27)			40 (54)		
		Stainless Steel	ft-lb (Nm)			20 (27)			40 (54)		
	Grout Filled Block	Carbon Steel	ft-lb (Nm)			15 (20)			25 (34)		
$h$	min. base material thickness	in.	3 inch (76 mm) or 1.3 times embedment, whichever number is greater								
Bolt Fracture Load	Carbon Steel		2900 lb <sup>4,6</sup>			7200 lb <sup>4,6</sup>			12400 lb <sup>4</sup>		
	HDG		no offering			no offering			12400 lb <sup>4</sup>		
	Stainless steel		2900 lb <sup>4,7</sup>			7200 lb <sup>4,7</sup>			12400 lb <sup>4</sup>		

Details		Bolt Size	5/8 (15.9)			3/4 (19.1)			1 (25.4)		
$d_{bit}$	nominal bit diameter <sup>2</sup>	in. (mm)	5/8			3/4			1		
$h_{min}/h_{nom}/h_{deep}$	minimum/standard/deep depth of embedment	in. (mm)	2-3/4 (70)	4 (102)	5-1/2 (140)	3-1/4 (83)	4-3/4 (121)	6-1/2 <sup>3</sup> (165)	4-1/2 (114)	6 (152)	9 (229)
$h_o$	minimum/standard/deep hole depth	in. (mm)	3-3/8 (86)	4-5/8 (117)	6-1/8 (156)	4 (102)	5-1/2 (140)	6-4/5 (173)	5-1/2 (140)	7 (178)	10 (254)
$d_h$	wedge clearance hole in fixture	in. (mm)	11/16 (17)			13/16 (21)			1-1/8 (29)		
$T_{inst}$ Recommended Installation Torque	Normal weight & Light weight Concrete	Carbon Steel HDG	ft-lb (Nm)			150 (203)			250 (339)		
		Stainless Steel	ft-lb (Nm)			150 (203)			235 (319)		
	Grout Filled Block	Carbon Steel	ft-lb (Nm)			65 (88)			120 (1663)		
$h$	min. base material thickness	in.	3 inch (76 mm) or 1.3 times embedment, whichever number is greater								
Bolt Fracture Load	Carbon Steel		19600 lb <sup>4</sup>			28700 lb <sup>4,6</sup>			$f_{ut} \geq 88 \text{ ksi}, f_y \geq 75 \text{ ksi}^5$		
	HDG		19600 lb <sup>4</sup>			28700 lb <sup>4</sup>			no offering		
	Stainless steel		21900 lb <sup>4</sup>			$f_{ut} \geq 76 \text{ ksi}, f_y \geq 64 \text{ ksi}^5$			$f_{ut} \geq 76 \text{ ksi}, f_y \geq 64 \text{ ksi}^5$		

- See Kwik Bolt 3 Product Line Table in Section 4.5.3.3 for a full list and anchor length and thread length configurations.
- Loads for Kwik Bolt 3 are applicable for both carbide drill bits (see Section 6.4.1) and matched tolerance Hilti DD-C diamond core bits in sizes ranging from 1/2 inch to 1 inch.
- The deep embedment depth for stainless steel Kwik Bolt 3 anchors is 6 inch (203 mm).
- Bolt fracture loads are determined by testing in a jig as part of product quality control. These values are not intended for design purposes.
- Bolt strength specified by minimum tensile and yield strength. Bolt fracture load not applicable.
- Bolt fracture load not applicable to carbon steel Countersunk Kwik Bolt 3. The tensile and yield strengths are,  $f_{ut} \geq 105 \text{ ksi}$  and  $f_y \geq 90 \text{ ksi}$ .
- Bolt fracture load not applicable to stainless steel Countersunk Kwik Bolt 3. The tensile and yield strengths are,  $f_{ut} \geq 90 \text{ ksi}$  and  $f_y \geq 76 \text{ ksi}$ .
- For 3/4 x 12,  $f_{ut} \geq 66 \text{ ksi}$  and  $f_y \geq 75 \text{ ksi}$ . Bolt fracture load not applicable.



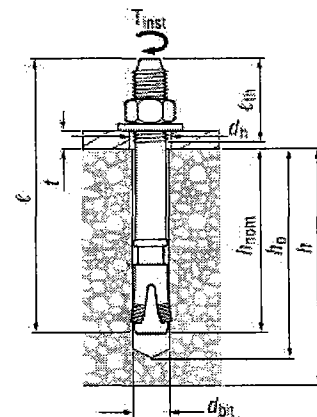

## ROOF PANEL INSTALLATION

1. Place the 1/4" thick lexan panel over the bows of the roof. Install edges into grooves as shown in Fig 1. There should be a 1/2" gap between panels.
2. See Fig 2. Place the pressure ribs with the two rubber bulb seals over the center joints. There can be a short gap at either end. Use the TEKS screws #14 x 1 1/2" (5 per pressure rib) & #14 x 1 1/2" (2 per pressure rib) to secure the pressure rib to the roof bow. The TEKS screw is self-drilling and tapping. A 3/8" nut driver with suitable power tool should be used.

### PROCEDURE:

1. Install center screw first-be sure pressure rib is centered. Use the #14 x 1 1/2" TEKS screw.
  2. Install next screws down, use the #14 x 1 1/2" TEKS screws.
  3. Press pressure rib down and install bottom screws, use the longer #14 x 1 1/2" TEKS screws.
3. See Figure 3. Slip the 55" long rubber J-channel over one edge of the flanged band. This band is used at each end of the roof. The edge of the band without the J-channel will be aligned to the outer edge of the last bow and on top of the 1/4" square bead. The band must be against the aluminum roof panel and the 1/4" square bead. Use the TEKS screws per each of these bands as follows.

### PROCEDURE:

1. Install center screw first-be sure band is centered. Use the #14 x 1 1/2" TEKS screw.
2. Install next screws down, use the #14 x 1 1/2" TEKS screws.
3. Press band down and install bottom screws, use the longer #14 x 1 1/2" TEKS screws.

BEFORE REMOVING PROTECTIVE FILMS FROM LEXAN PANEL DETERMINE WHICH SURFACE IS TO BE EXPOSED TO THE OUTSIDE

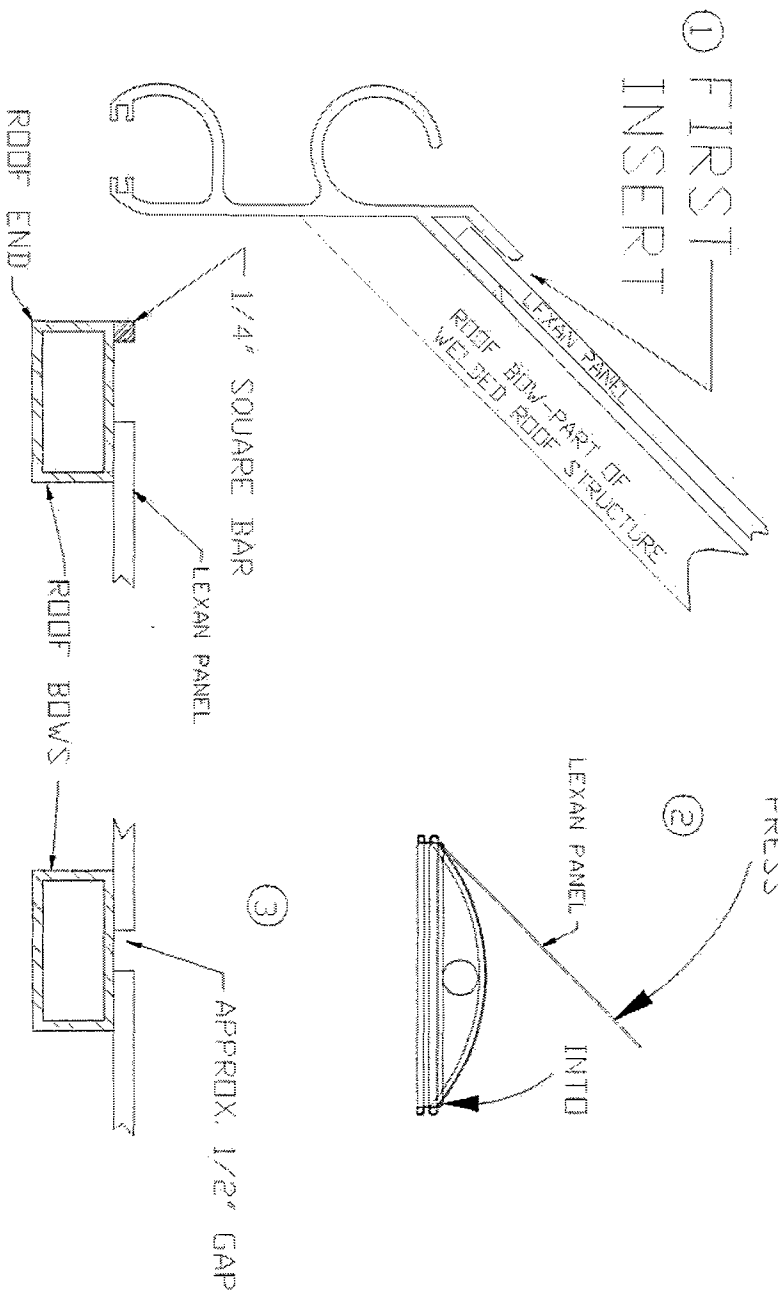
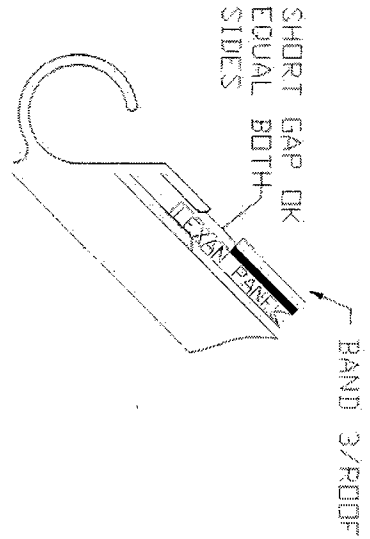
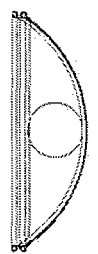
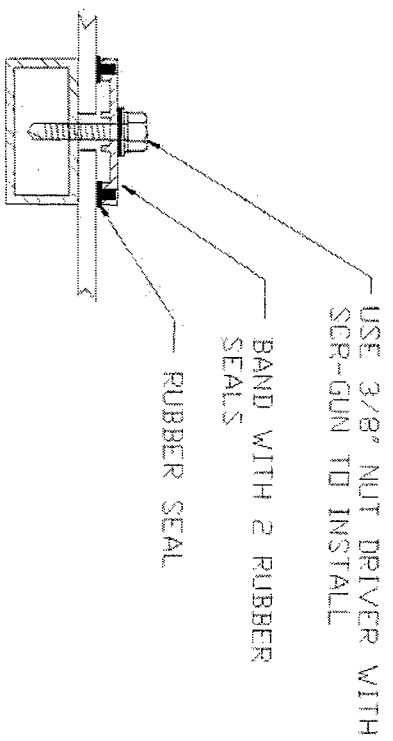

FIG 1





BAND WITH SEALS USED AT 3 CENTER BOWS ONLY  
BAND IS EASILY FORMED



TEKS (SELF DRILLING) SHEET METAL SCREW (SUPPLIED)  
-HAS A HEX HEAD WITH NEOPRENE WASHER FLANGE  
#14 X 1 1/2 (7 QTY)

- PROCEDURE:
1. INSTALL CENTER SCREW FIRST - BE SURE BAND IS CENTERED
  2. INSTALL NEXT SCREWS DOWN
  3. PRESS BAND DOWN AND INSTALL BOTTOM SCREWS FULLY

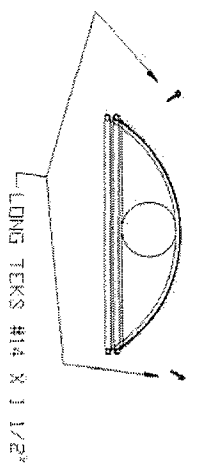

INSTALL SEALING BANDS AT 3 CENTER JOINTS

FIG 2

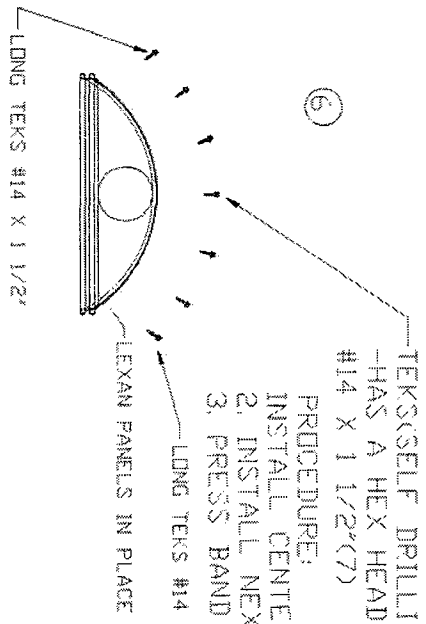

⑥  
 -TEKS(SELF DRILLING) SHEET METAL SCREW(SUPPLIED)  
 -HAS A HEX HEAD WITH NEOPRENE WASHER FLANGE  
 #14 X 1 1/2"(7)  
 PROCEDURE:  
 1. INSTALL CENTER SCREW FIRST-BE SURE BAND IS CENTERED  
 2. INSTALL NEXT SCREWS DOWN  
 3. PRESS BAND DOWN AND INSTALL BOTTOM SCREWS FULLY

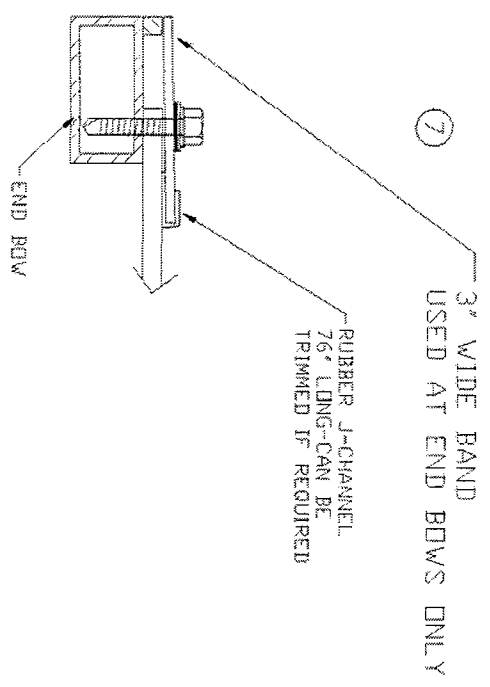
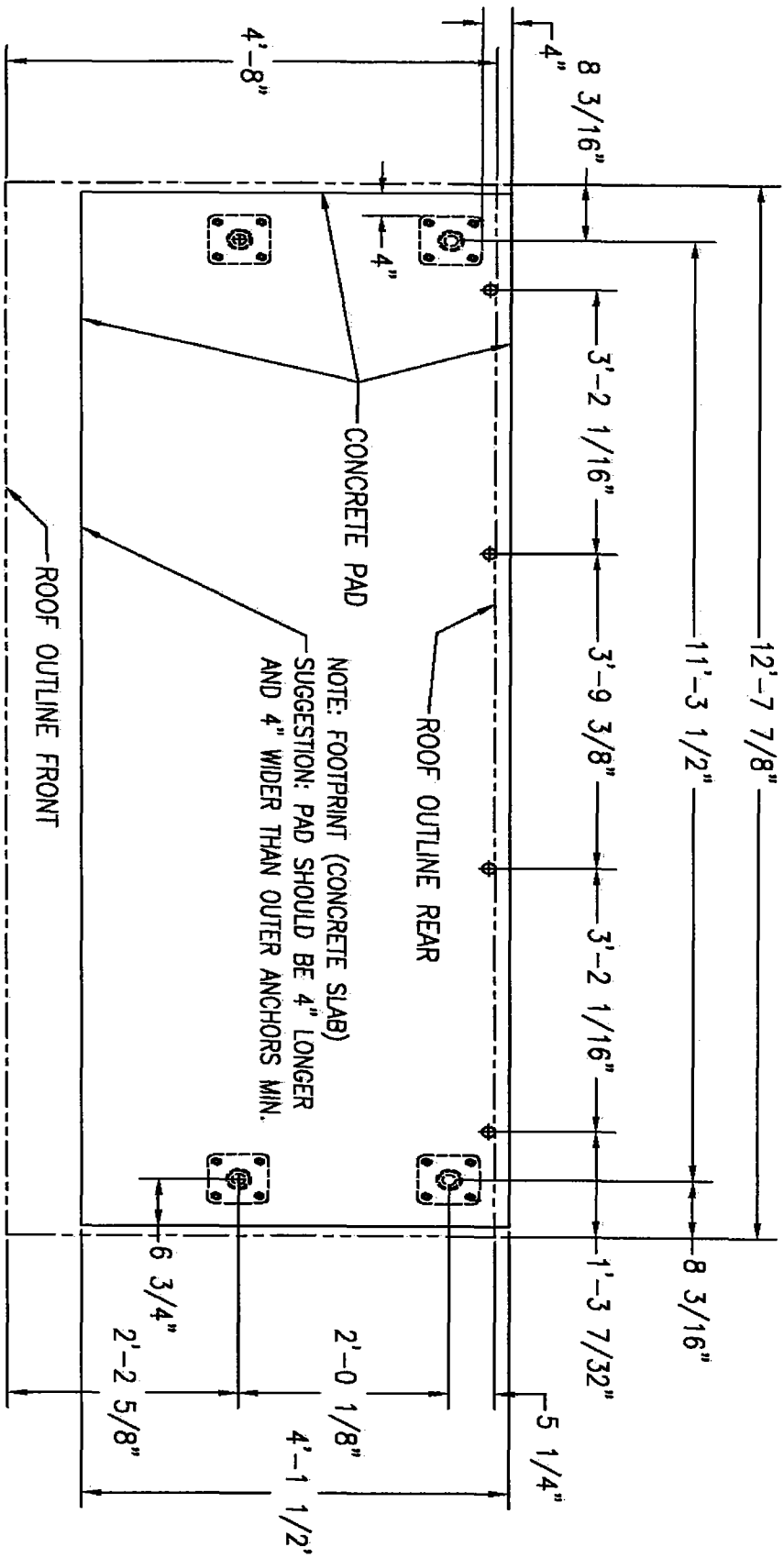

FIG 3  
 INSTALL BANDS  
 AT ROOF ENDS

## **ROOF INSTALLATION**

1. **Slide the four 18" long shoes into the four support posts.**
2. **Raise the roof (weight-175 pounds) Raise the roof (weight-200 pounds)with the rear glass insertion groove at the back, and position the post assemblies under he roof cross beams. The roof should overhang the dual post assemblies more toward the street. The post assembly with the access hole near the bottom must be placed at the right back of the shelter.**
3. **The SJO electrical cord must be dropped down the right back support pipe. This electrical cord is shipped attached to the roof crossbeam. Lower the roof down onto the support posts.**
4. **Insert and tighten eight (8) each 3/8-16 x 1" Hex Head Bolts, 3/8 Lockwashers and 3/8 flatwashers at the top of each post assembly.**
5. **Level the roof by placing a carpenter's level on the roof's gutter. The roof height can be increased if desired. Drill a .50(1/2") diameter hole completely through the shoe. Install and tighten the 1/2-13 x 4" Hex Head Bolt at each post. Use the self-locking hexnut to secure. The small 1/4 diameter may be used initially to level the roof. Drill a .221(#2) diameter hole through the shoe. Hammer in a drive screw #14 x 3/4" long completely through the shoe. However it is not required that this drive screw be used.**
6. **Plumb each post assembly. The pipe to pipe centerline measurement must be 24 1/8" for fitting of the end glass later. Pipe to pipe inside measurement is 20 5/8". Check this dimension at the pipe bottom before tightening the anchors.**
7. **With a 1/2" diameter masonry drill, make four holes in the concrete using each support leg shoe as a hole locator. These holes are to be 3 1/2" deep. Clean out the holes.**
8. **Place the 1/2" size Hilti anchors into the holes. Tighten the anchors to set. Secure each shoe with four anchors.**
9. **Removing the access cover from the support post can access the SJO cord. Make line connections from 110 vac 60c power source. NOTE: There is a light switch in the roof crossbeam over this support post. Force out the plastic light lenses for access to the switch.**



FLOOR PLAN

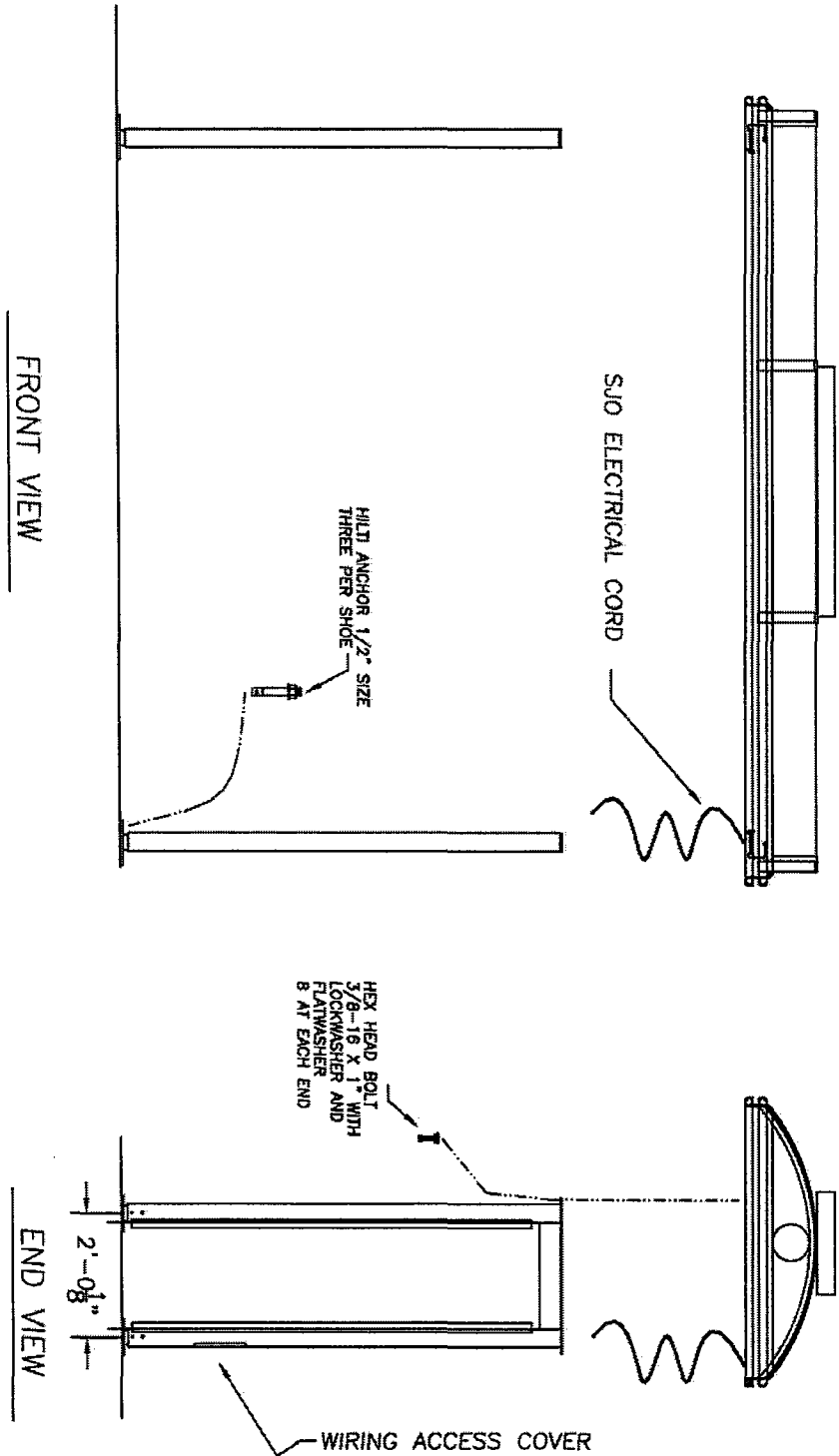

ROOF INSTALLATION-TYPICAL

## **REAR GLASS INSTALLATION**

- 1. Drop a plumb line from the rear glass insertion groove of the roof perimeter. Do this at the back right and the back left of the shelter. Mark the concrete near both ends of the roof and snap a chalk line on the concrete under the back of the shelter. The rear glass support/anchor assemblies will be inserted on this line. Mark the chalk line at the intervals shown on the elevation drawings. These marks will be the proper spacing for the support/anchor assemblies.**
- 2. Drill five (5) 1 1/4 diameter holes into the concrete on the marks with a masonry drill. These holes will need to be at least 6" deep and may penetrate into the grade below the concrete for the anchor threaded rod clearance.**
- 3. Place the bottom glass support/anchor assemblies into the holes. The total height of the glass is 79". Measure from inside the glass insertion groove to the glass support anchor. Rotate the threaded rod inside the anchor to adjust height. Tighten the 3/4-10 hexnut to expand and secure anchor. Slide glass up into glass insertion groove of roof and onto bottom glass support/anchor assemblies (separate clip can be slid off). Place rubber setting u-channels onto the support and under and alongside the glass. Replace clip. Leave a gap of 5/8" between glass panes for the side glass clip(See Dwg 1094)**
- 4. Disassemble the side glass clip. Place one part inside the glass and one part outside the glass. The part with the exposed screw is to be outside the glass (to back). Replace screw.**

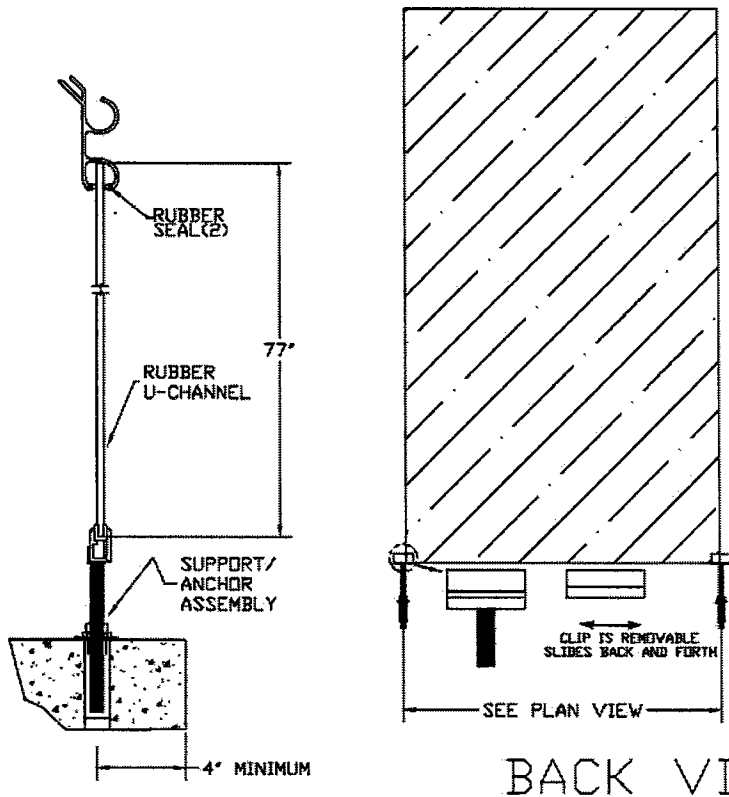
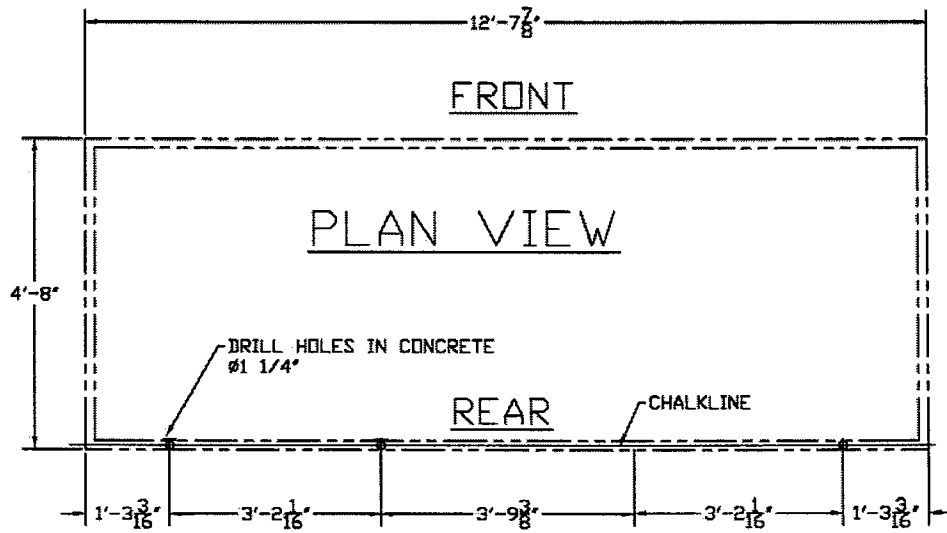

GLASS INSTALLATION (TYPICAL)

## END GLASS INSTALLATION

1. Apply the supplied Impermeable Tape (GE# G3660C) to the top and bottom of the laminated glass to protect the edges from moisture.
2. Slide the glass fully into either of the glass extrusions that are bolted to the end posts. Then insert glass into opposite extrusion.

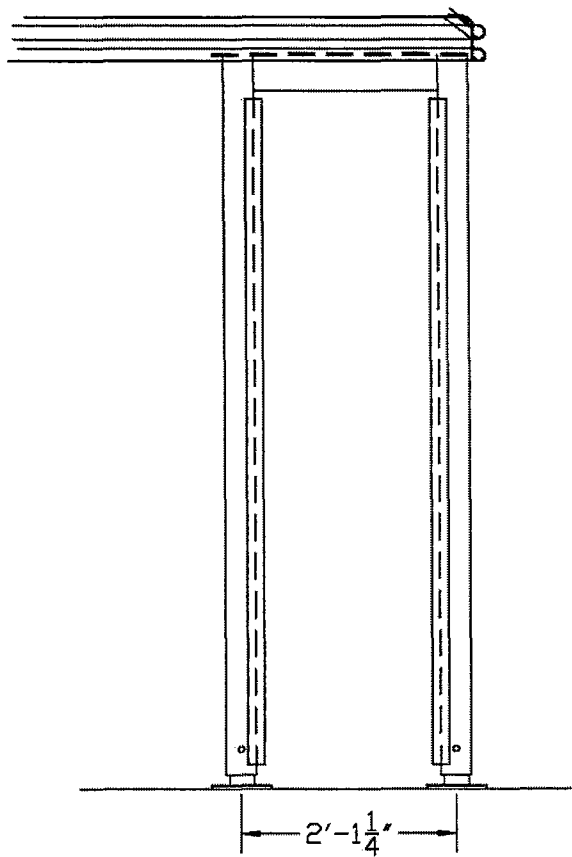
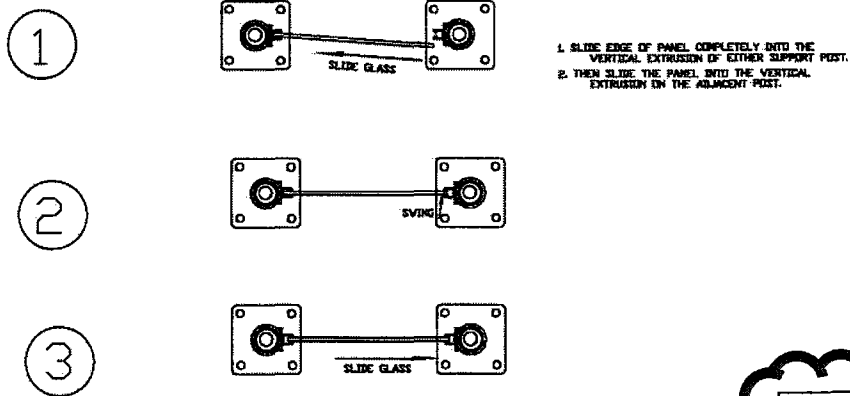

Impermeable tape on both ends (G3660C)



## MAP CASE INSTALLATION

### NOTES: READ ALL INSTRUCTIONS BEFORE INSTALLING THE MAP CASES

*It is recommended that the map cases be installed on the glass in a horizontal position (lying down). This is so that the proper pressure can be applied to 3M VHB Tape to ensure proper adhesion. Use a "J" Roller to ensure proper pressure is distributed evenly over the tape. (See \*Pressure). Use the 3M Primer 94 (supplied) to promote adhesion of the 3M tape to the glass (See \*Application Technique for 3M Primer 94).*

**Surface Preparation:** The bonding surface must be relatively clean and dry. Contaminated surfaces should be cleaned with a 50/50 Isopropyl Alcohol and water mixture. A clean lint-free cloth should be used. Refer to 3M Technical Bulletin "Surface Preparation for 3M™ VHB™ Tape Applications" for additional details and suggestions. (Page 19-22).

**Note:** Carefully read and follow manufacturers when handling cleaning solvents.

**\*Pressure:** Bond strength is dependent upon the amount of adhesive-to-surface contact developed. Firm application pressure develops better adhesive contact and helps improve bond strength. Typically, good surface contact can be attained by applying enough pressure to insure that the tape experiences approximately 15 psi of pressure. Either roller or platen pressure can be used. Note that rigid surfaces may require 2 or 3 times that much pressure to make the tape experience 15 psi.

**\*Temperature:** Ideal application temperature range is 70°F to 100°F (21°C to 38°C). Pressure sensitive adhesives use viscous flow to achieve substrate contact area. Minimum suggested application temperature is 50°F (10°C).

**Note:** Initial tape application to surfaces at temperatures below these suggested minimums is not recommended because the adhesive becomes too firm to adhere readily. To obtain good performance with all 3M™ VHB™ Tapes, it is important to ensure that the surfaces are dry and free of condensed moisture.

**\*Time:** After application, the bond strength will increase as the adhesive flows onto the surface. At room temperature approximately 50% of ultimate bond strength will be achieved after 20 minutes, 90% after 24 hours and 100% after 72 hours. This flow is faster at higher temperatures and slower at lower temperatures. Ultimate bond strength can be achieved more quickly (and in some cases bond strength can be increased) by exposure of the bond to elevated temperatures (e.g. 150°F [66° for 1 hour). This can provide better adhesive wetout onto the substrates. Abrasion of the surfaces or the use of primers/ adhesion promoters can also have the effect of increasing bond strength and achieving ultimate bond strength more quickly.

**\*Application Technique for 3M Primer 94:** Shake 3M primer 94 well before using. Apply a thin uniform coating to the bonding surface using the minimum amount that will fully coat the surface. Allow 3M primer 94 to dry thoroughly before applying tape. This is usually accomplished in 5 minutes at room temperature. Be sure the primed surface remains free from contaminants prior to applying the tape. Porous surfaces may require 2 applications of 3M primer 94 for uniform coverage and good adhesion. Allow first application of primer to dry before applying the second coat.

## MAP CASE INSTALLATION

### Installation Steps:

Remove the side frame from the map case.

Remove the Back Panel and Glass.

Set the map case frame on the glass in the desired position.

Mark the perimeter of the map case frame where the tape will make contact with the glass.

Remove the map case and apply the 3M Primer 94. See \*Application Technique for 3M Primer 94.

Remove about 2" of the red liner from the 3M tape on all sides.

Place the map case back onto the glass. Before peeling the remaining red liner from the 3M tape ensure the map case is centered on the glass and level. Remove the liner.

Use the "J" roller to apply pressure on the 3M tape from the inside. See \* Pressure. Allow to cure. See \*Time.

Mount the back sheet to the make fame.

Reinstall the glass and the removable frame.

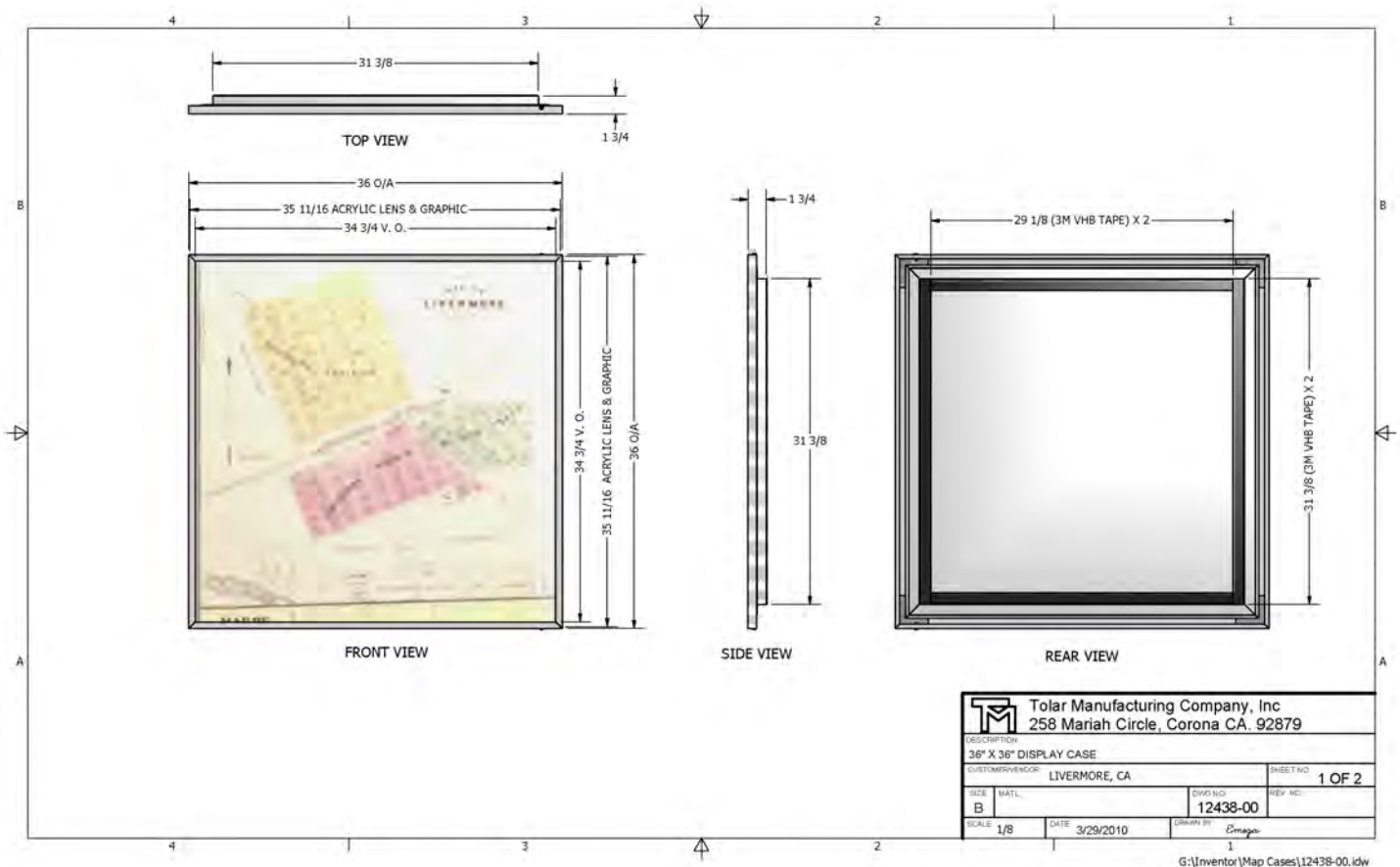

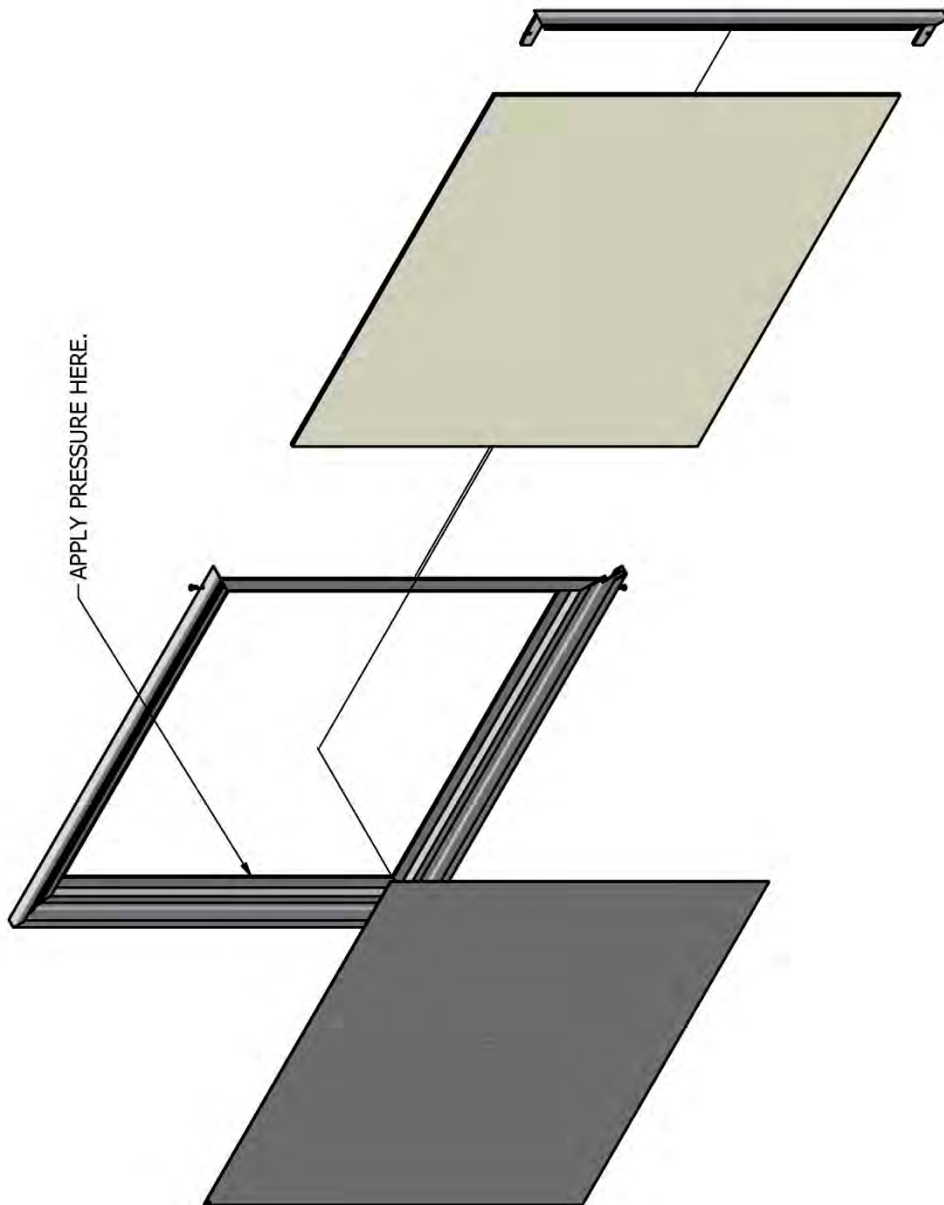

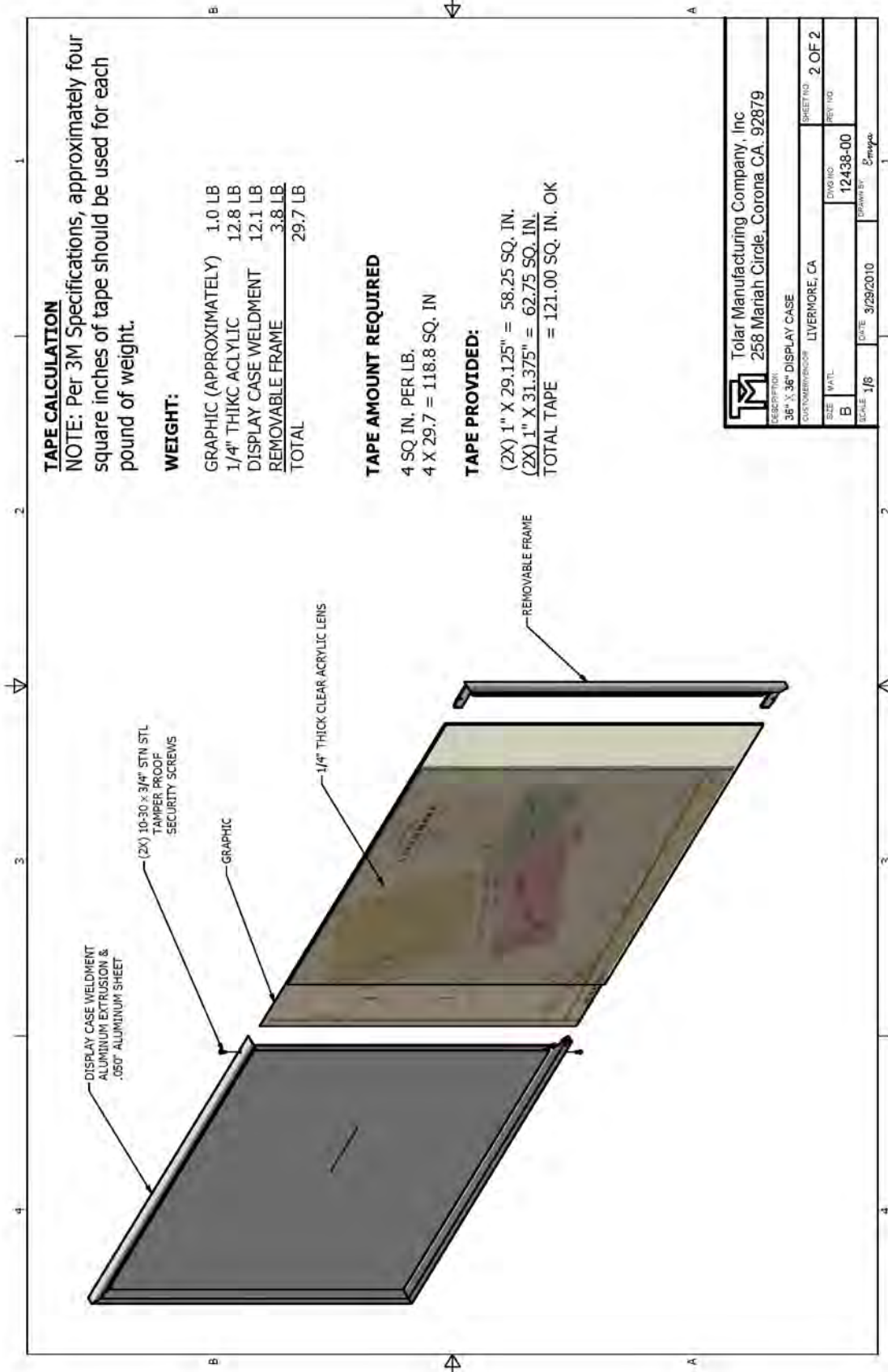

**TAPE CALCULATION**

NOTE: Per 3M Specifications, approximately four square inches of tape should be used for each pound of weight.

**WEIGHT:**

GRAPHIC (APPROXIMATELY)	1.0 LB
1/4" THICK ACRYLIC	12.8 LB
DISPLAY CASE WELDMENT	12.1 LB
REMOVABLE FRAME	3.8 LB
<b>TOTAL</b>	<b>29.7 LB</b>

**TAPE AMOUNT REQUIRED**

4 SQ IN. PER LB.  
 4 X 29.7 = 118.8 SQ. IN

**TAPE PROVIDED:**

(2X) 1" X 29.125" = 58.25 SQ. IN.  
 (2X) 1" X 31.375" = 62.75 SQ. IN.  
 TOTAL TAPE = 121.00 SQ. IN. OK

Tolar Manufacturing Company, Inc 258 Mariah Circle, Corona CA, 92879			
DESCRIPTION	36" X 36" DISPLAY CASE		
CUSTOMER/SKETCH	LIVERMORE, CA		
SIZE	DWG NO	DRAWN BY	SHEET NO
B	12438-00	1	2 OF 2
SCALE	DATE	REVISED	REVISED
1/8	3/29/2010	1	1

G:\Inventor\Map Cases\12438-00.dwg

# 3M

## Surface Preparation for 3M™ VHB™ Tape Applications

Technical Bulletin

April, 2007

**Summary** Most substrates are best prepared by cleaning with a 50:50 mixture of isopropyl alcohol (IPA) and water\* prior to applying 3M™ VHB™ Tapes.

Exceptions to this general procedure that may require additional surface preparation include:

- **Heavy Oils:** A degreaser or solvent-based cleaner may be required to remove heavy oil or grease from a surface and should be followed by cleaning with IPA/water.
- **Abrasion:** Abrading a surface, followed by cleaning with IPA/water, can remove heavy dirt or oxidation and can increase surface area to improve adhesion.
- **Adhesion Promoters:** Priming a surface can significantly improve initial and ultimate adhesion to many materials such as plastics and paints.
- **Porous Surfaces:** Most porous and fibred materials such as wood, particleboard, concrete etc. need to be sealed to provide a unified surface.
- **Unique Materials:** Special surface preparation may be needed for glass and glass-like materials, copper and copper containing metals and plastics or rubber that contain components that migrate (e.g. plasticizers).

### General Procedure

- To obtain optimum adhesion, the bonding surfaces must be well unified, clean and dry. Typical surface cleaning solvents are IPA/water mixture (rubbing alcohol) or heptane.\* (Steps A and B)
- Bond strength is dependent upon the amount of adhesive-to-surface contact developed. Firm application pressure develops better adhesive contact and helps improve bond strength. (Steps C and D)  
Generally, this means that the tape should experience at least 15 psi (100 kPa) in roll down or platen pressure. (Sources- page #4)
- After application, the bond strength will increase as the adhesive flows onto the surface. At room temperature, approximately 50% of the ultimate strength will be achieved after 20 minutes, 90% after 24 hours and 100% after 72 hours. In some cases, bond strength can be increased and ultimate bond strength can be achieved more quickly by exposure of the bond to elevated temperatures (e.g. 150°F [66°C] for 1 hour).

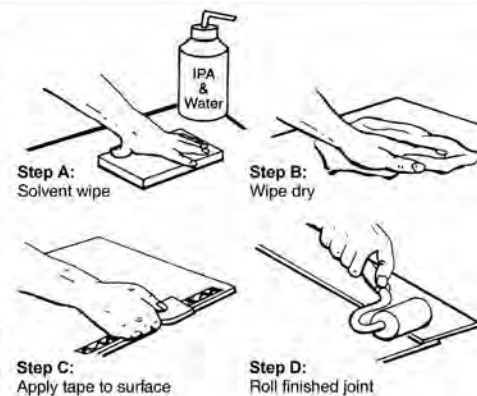

Typical Bond Build Over Time

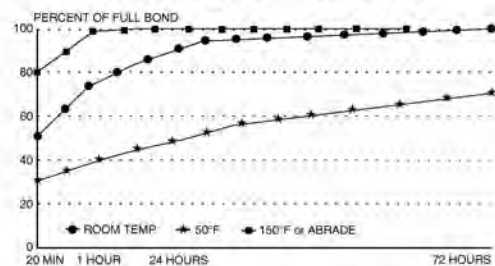

\*Note: These cleaner solutions contain **greater than 250 g/l** of volatile organic compounds (VOC). Please consult your local Air Quality Regulations to be sure the cleaner is compliant. When using solvents, be sure to follow the manufacturer's precautions and directions for use when handling such materials.

(1)

## Technical Bulletin

### Surface Preparation for 3M™ VHB™ Tape Applications

**Heavy Oils** On surfaces with a light oily film, or other light contamination, the 50:50 IPA/water solution is usually adequate. Where heavy oils or grease are present, a “degreasing” solvent such as 3M™ Prep Solvent 70, 3M™ Citrus Base Cleaner, mineral spirits, naphtha or similar solvents are suggested to cut the oil. This should always be followed with an IPA/water cleaning to help ensure that any residue or film is removed.\*

**Abrasion** Abrading a surface can serve several functions:

- Remove heavy levels of dirt or oxide from metals or paints (e.g. galvanized steel).
- Create additional surface area that can increase adhesion.
- Smooth a surface to obtain more flatness, allowing improved contact area.

Abrasion often helps adhesion to paints and plastics. When abrading, it is important for tapes to have a finely abraded surface. Very small scratches in the surface, generated with circular motion rather than straight-line motion, are most desirable. A surface with many micro-scratches in it can have up to 40% additional available surface area, translating to higher ultimate strength and greater initial adhesion. Scotch-Brite® Hand Pads (such as 7447 Maroon or Heavy Duty Green) are good for achieving the right level of abrasion. Tools such as a power palm sander will assist on large jobs. Avoid grinding a surface with coarse abrasive materials, since they may create too rough of a texture for the adhesive to adequately flow into the surface. Always clean the surface with the IPA/water solution or additional methods previously described, and be certain that all loose particles are removed prior to bonding.

Exceptions to these abrading guidelines are 3M™ VHB™ Tapes 4932 and 4952, as they typically perform best on smooth glossy surfaces and abrasion may reduce the bond strength.

**Adhesion Promoters** Priming a surface can significantly improve initial and ultimate adhesion to many materials such as plastics and paints because of their low surface energy or the additives they may contain. A primer creates a new surface for 3M™ VHB™ Tape to adhere to and can also create a layer that may impede the migration of additives that may be present in a material. It is important for the user to determine the suitability of the 3M™ VHB™ Tape, the adhesion promoter and the application process.

**Porous Surfaces** Rough, porous or fibered materials such as wood, particleboard, cement, etc., have an open surface and require sealing to provide a unified surface for tape bonding. Common sealing materials would include paint, varnish or other hard surface coatings. Fast drying 3M™ Rubber and Vinyl Spray 80 can also be used to unify the surface and improve the tape bond.

**Unique Surfaces** Glass, stone, ceramic or other siliceous materials are hydrophilic (water-loving) by nature. Normally, the hydrophilic nature makes pressure sensitive adhesive bond durability susceptible to change under high humidity or exposure to moisture. In basic terms, water vapor can undercut the tape bond and interfere with the normal adhesion forces. Silane coupling agents, added to the IPA/water cleaning solution, can help reduce the “water-loving” tendency of these surfaces and enhance the tape bond in high moisture environments.

Copper, brass, and bronze are prone to oxidation even after the 3M™ VHB™ Tape is applied. To prevent a weakening of the bond, a lacquer or varnish should be applied to these surfaces. Be sure to test the tape bond to the sealer on a metal surface to verify good adhesion.

Flexible PVC (vinyl) contains plasticizers that can migrate into the tape and affect adhesion. There are several 3M™ VHB™ Tapes that are formulated to be resistant to plasticizer migration, or 3M™ Scotch-Grip™ Plastic Adhesive 2262, thinned, can serve as a barrier to migration. Rubber materials (e.g. EPDM, neoprene) can have low surface energy and may also contain plasticizers and oils. These require the use of an adhesion promoter for stable bond strength. Test for compatibility with flexible PVC and rubber materials by aging bonded samples for a week at 150°F (66°C) and check for softening of the adhesive, discoloration or reduction in bond strength.

\*Note: These cleaner solutions contain greater than 250 g/l of volatile organic compounds (VOC). Please consult your local Air Quality Regulations to be sure the cleaner is compliant. When using solvents, be sure to follow the manufacturer’s precautions and directions for use when handling such materials.

## Technical Bulletin

### Surface Preparation for 3M™ VHB™ Tape Applications

**Suggested Primers** The table below offers suggested primers and alternative methods that commonly require primers, adhesion promoters or other surface treatments for successful use with 3M™ VHB™ Tapes. This list is not intended to be fully comprehensive but may be useful for many applications. It is very important for the user to determine the suitability of the 3M™ VHB™ Tape, primer and application process and compliance with local Air Quality Regulations.

Surface	Concern	Suggested Primer	Alternatives
Steel or Aluminum	Surface must be clean	None suggested	Abrasion may clean surface; 3M™ Adhesion Promoter 111 for increased adhesion.
Copper, Brass, Bronze	Oxidation after bonding	Lacquer or varnish <sup>(b)</sup>	Architectural grade coatings
Concrete, Brick	Non-unified or rough surface, moisture	3M™ Rubber and Vinyl Spray 80	Concrete sealer, paint
Glass, Stone, Ceramic Tile	High humidity, moisture	3M™ Silane Glass Treatment AP 115 or similar silane coupling agent in IPA/water mixture <sup>(a)</sup>	3M™ Primer 94
Wood (soft, hard particle board, etc.)	Weak fiber layer on surface (e.g., low surface strength)	3M™ Rubber and Vinyl Spray 80, 3M™ Fastbond™ 30 Contact Adhesive	Urethane paint, varnish
Plastics: Polyolefin	Low adhesion	3M™ Primer 94 (additional surface preparation may be required)	Flame treatment, Corona treatment
Non-olefin	Additives, low adhesion	3M™ Primer 94, 3M™ Scotch-Grip™ Plastic Adhesive 2262 <sup>(a)</sup>	Abrade or 3M™ VHB™ Tapes 4832/4852/5925/5952/5962
Polyurethane (Molded or Rubber)	Mold release, low adhesion	3M™ Adhesion Promoter N-200J, 3M™ Scotch-Grip™ Plastic Adhesive 1099	Abrade and prime
Rubber: Neoprene, Santoprene	Migrating oils	3M™ Primer 94, 3M™ Scotch-Grip™ Plastic Adhesive 1099	3M™ Weather Strip Tapes
EPDM	Low adhesion	3M™ Primer 94	3M™ Weather Strip Tapes
Paints	Low adhesion	3M™ Adhesion Promoter 111	Abrade or 3M™ VHB™ Tapes 4832/4852/5925/5952/5962, or 3M™ Primer 94, 3M™ Scotch-Grip™ Plastic Adhesive 2262 <sup>(a)</sup> , 3M™ Adhesion Promoter N-200J
Coil Coated Aluminum	Low adhesion	3M™ Adhesion Promoter 111	Abrade or 3M™ VHB™ Tapes 4832/4852/5925/5952/5962, or 3M™ Primer 94, 3M™ Scotch-Grip™ Plastic Adhesive 2262 <sup>(a)</sup> , 3M™ Adhesion Promoter N-200J
Flexible PVC (Vinyl)	Plasticizer migration	3M™ Scotch-Grip Plastic Adhesive 2262 <sup>(a)</sup> , 3M™ Rubber and Vinyl Spray 80	3M™ VHB™ Tapes 4845 and 4941 (test for migration)

**Note:** These primers contain greater than 250 g/l of volatile organic compounds (VOC). Please contact your local Air Quality Regulations to be sure these primers are compliant.

<sup>(a)</sup>3M™ Scotch-Grip™ Plastic Adhesive 2262 contains 196 g/l VOC.

<sup>(b)</sup>See supplier information.

#### Primer Source and Description

- 3M™ Primer 94, 3M™ Adhesion Promoter 111 and 3M™ Silane Glass Treatment AP 115 are available through distributors that carry 3M™ VHB™ Tapes.
- 3M™ Scotch-Grip™ Plastic Adhesive 2262 must be thinned in acetone or MEK\* in a 1:5 or 1:10 ratio (e.g., 1 part Scotch-Grip plastic adhesive 2262 to 5 parts acetone or MEK). The product is available premixed in either acetone or MEK from: PRC DeSoto at (317) 290-1600. 3M™ Scotch-Grip™ Plastic Adhesive 2262T, thinned in 10:1 MEK solution or 3M™ Scotch-Grip™ Plastic Adhesive 2262TA, thinned in 10:1 acetone solution.\* When diluted in acetone at this ratio, this material contains 196 g/l VOC.\*
- Diluted 3M™ Scotch-Grip™ Plastic Adhesive 1099 must be thinned in acetone\* in a 1:3 ratio (e.g., 1 part Scotch-Grip plastic adhesive 1099 to 3 parts acetone). This thinned material contains zero VOC's when diluted in these ratios.
- 3M™ Adhesion Promoter N-200J is available from PRC DeSoto at (317) 290-1600.
- Silane Coupling Agent is also available premixed in a 91:9 IPA/water solution or as a concentrate. A 0.5 wt. % level of silane\* adhesion promoter diluted in a 91:9 IPA/water cleaning solution has been found to be sufficient.

Suggested Sources for Silane Coupling Agents:

Custom-Pak Products, Inc. (262) 251-6180 available premixed in IPA/water  
Lancaster Synthesis, Inc. (603) 889-3306 available 100% concentrated

\*Note: Be sure to read and follow silane and solvent manufacturer's precautions and directions for use for proper handling and storage information.

## Technical Bulletin

### Surface Preparation for 3M™ VHB™ Tape Applications

**Run an Evaluation** Because 3M cannot anticipate all of the different possible surfaces and contaminants that may exist, it is imperative that the user conduct an evaluation to determine the suitability of 3M™ VHB™ Tapes, surface preparations procedures, and any other processes that may have an influence on the tape or the bonded parts. Likewise, where there are any changes in plastic or paint formulation, or suppliers of these materials, it is advisable to run evaluations to ensure that the change has not influenced the compatibility of the surface with 3M™ VHB™ Tapes.

**Sources** **Hand held J-Roller:**  
Rockler Woodworking and Hardware  
Phone: (800) 279-4441 Specify #39463  
www.rockler.com

**Product Use** All statements, technical information and recommendations contained in this document are based upon tests or experience that 3M believes are reliable. However, many factors beyond 3M's control can affect the use and performance of a 3M product in a particular application, including the conditions under which the product is used and the time and environmental conditions in which the product is expected to perform. Since these factors are uniquely within the user's knowledge and control, it is essential that the user evaluate the 3M product to determine whether it is fit for a particular purpose and suitable for the user's method of application.

**Limited Warranty** 3M warrants for 24 months from the date of manufacture that 3M™ VHB™ Tape will be free of defects in material and manufacture. 3M MAKES NO OTHER WARRANTIES, EXPRESS OR IMPLIED, INCLUDING BUT NOT LIMITED TO, ANY IMPLIED WARRANTY OF MERCHANTABILITY OR FITNESS FOR A PARTICULAR PURPOSE. This limited warranty does not cover damage resulting from the use or inability to use 3M™ VHB™ Tape due to misuse, workmanship in application, or application or storage not in accordance with 3M recommended procedures.

**Limitation of Remedies and Liability** If the 3M™ VHB™ Tape is proved to be defective within the warranty period stated above, THE EXCLUSIVE REMEDY, AT 3M'S OPTION, SHALL BE TO REFUND THE PURCHASE PRICE OF OR TO REPAIR OR REPLACE THE DEFECTIVE 3M™ VHB™ TAPE. 3M shall not otherwise be liable for loss or damages, whether direct, indirect, special, incidental, or consequential, regardless of the legal theory asserted, including negligence, warranty, or strict liability.

**ISO 9001:2000**

This Industrial Adhesives and Tapes Division product was manufactured under a 3M quality system registered to ISO 9001:2000 standards.

**3M**

**Industrial Business**  
**Industrial Adhesives and Tapes Division**  
3M Center, Building 21-1W-10, 900 Bush Avenue  
St. Paul, MN 55144-1000  
800-362-3550 • 877-369-2923 (fax)  
www.3M.com/industrial



*Recycled Paper*  
40% pre-consumer  
10% post-consumer

Scotch-Brite is a registered trademark of 3M Company.  
3M, VHB and Scotch-Grip are trademarks of 3M Company.  
Printed in U.S.A.  
©3M 2007 70-0704-8701 5 (4/07)

(4)



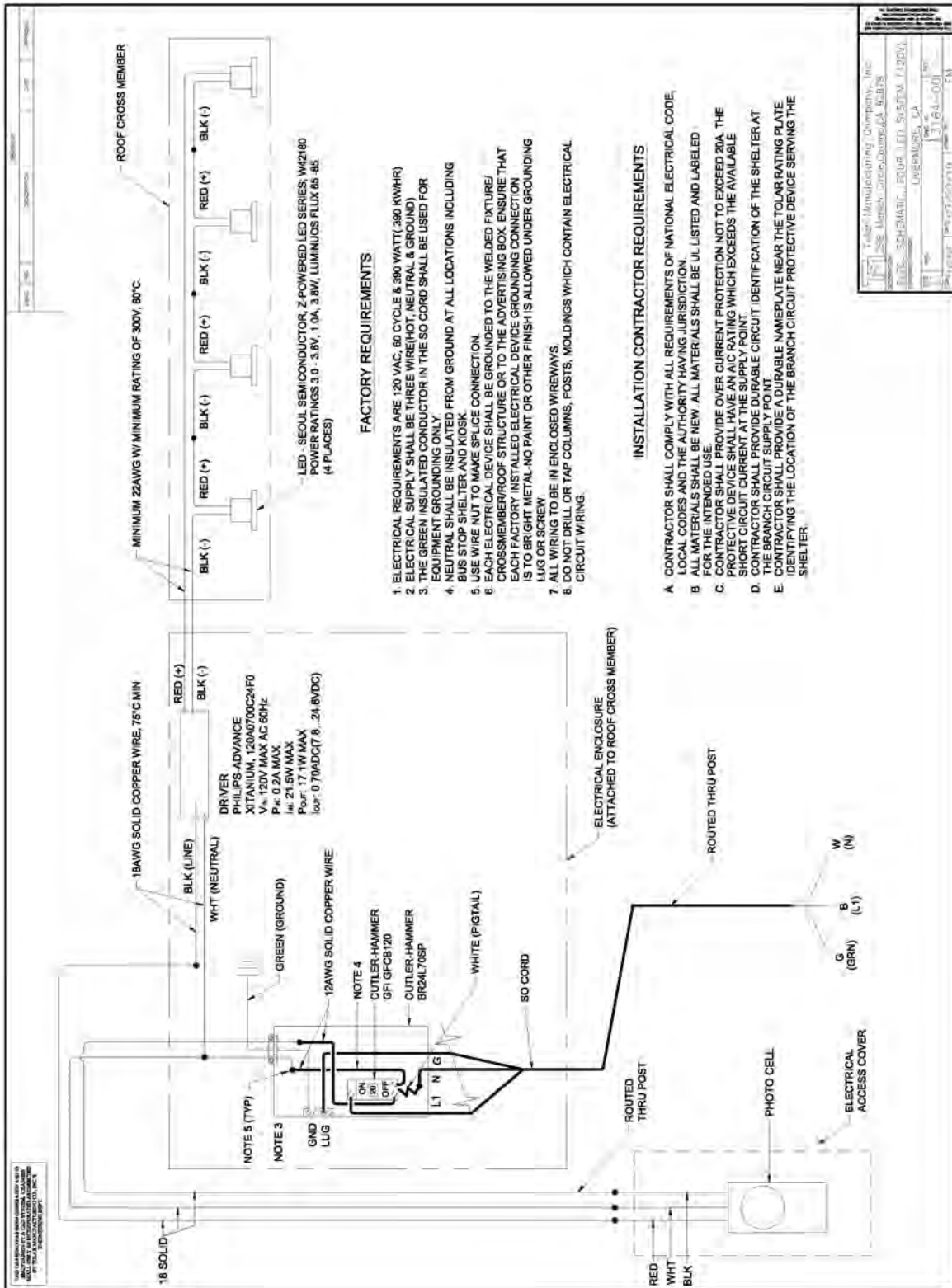

APPENDIX C

PROPOSED LAVTA AGREEMENT

THIS AGREEMENT, ("Agreement") made and entered into this \_\_\_\_ day of \_\_\_\_\_, 2018, by and between the **Livermore Amador Valley Transit Authority** (Authority), and \_\_\_\_\_ (Contractor)

## WITNESSETH

WHEREAS, Authority desires to obtain a firm to provide On-Call Bus Shelter Installation, Removal and Related Services and has issued a Request for Proposals dated \_\_\_\_\_, 2017 (which is attached hereto and incorporated as Attachment 1); and

WHEREAS, Contractor is qualified and willing to provide said Services and has submitted a proposal dated \_\_\_\_\_, 2017 (which is attached hereto and incorporated as Attachment 2);

**NOW, THEREFORE**, Authority and Contractor agree as follows:

**1. RENDITION OF SERVICES**

The Contractor agrees to perform services to Authority in accordance with the terms and conditions of this Agreement.

**2. SCOPE OF SERVICES**

Subject to the terms and conditions set forth in this Agreement, Contractor shall provide the services described in Attachment 1, as supplemented by Attachment 2, except when inconsistent with Attachment 1.

**3. SCHEDULE AND TIME OF COMPLETION**

The Contractor's performance of services for each Task Order shall commence upon receipt of written authority to proceed from LAVTA's Project Manager for the respective Task Order and the Contractor shall complete the services within the time frame specified in the Task Order.

**B. Agreement Performance Period**

Task Orders may be issued against this Agreement any time during the one-year base term, from the effective date of this Agreement, with LAVTA's unilateral option to extend this period for up to two additional one-year terms. Terms of individual Task Orders may exceed the Agreement term. Task Orders will be issued on a negotiated not-to-exceed price based on the Contractor's prices set forth in Attachment 2 and individual project requirements. This Agreement will remain in full force and effect until all outstanding services under the Task Orders are completed or terminated.

It is further understood that the base term of the Agreement or any option term(s) granted thereto are subject to the LAVTA's right to terminate the Agreement in accordance with Section 14 of this Agreement.

**4. COMPENSATION AND METHOD OF PAYMENT**

The Contractor agrees to perform all of the services included in Section II at the rates quoted in Attachment 2, Appendix A Price Proposal Form for the not-to-exceed price of Four Hundred Thousand Dollars (\$400,000). The compensation amounts shall include all labor, materials, taxes, profit, overhead, insurance, subcontractor costs and all other costs and expenses incurred by the Contractor in the performance of the services under this Agreement.

Additional services requested by the Authority shall be compensated in accordance with the fully burdened labor rates quoted in Attachment 2.

The Authority shall make payment for each completed project within 30 days of receipt of proper statements or invoices for the work performed in full conformance with the solicitation requirements, and approved by LAVTA's Director of Finance or Executive Director. The Authority reserves the right to withhold payment to the Contractor if the Authority determines that the quantity or quality of the work performed is unacceptable. The Authority shall provide written notice to the Contractor within 10 business days of the Authority's decision not to pay and the reasons for non-payment.

Payments for all items shall include labor, taxes, storage, transportation, delivery, warranty, insurance, materials, profit, subcontractor costs, overhead and all other costs associated with provision of the services.

For invoices related to Task Orders, each invoice must describe the Task Order, the services performed, the personnel performing these services, the hours worked and the applicable hourly rates of compensation. Submitted documentation must correspond to the price proposals specified in Consultant's proposal. An invoice for a Task Order may only be submitted once the Contractor has completed all work for a Task Order.

For invoices related to on-call work performed in addition to specified Task Orders as described above, the on-call work may be billed to LAVTA once a month.

All invoices should be sent to: Accounts Payable

Livermore Amador Valley Transit Authority  
1362 Rutan Court, Suite 100  
Livermore, CA 94551

Contractor represents that Contractor's taxpayer identification number (TIN) is as evidenced by a completed Federal Form W-9.

**5. CONTRACTOR'S KEY PERSONNEL**

It is understood and agreed by the parties that at all times during the term of this Agreement that \_\_\_\_\_ shall serve as the primary staff person of Contractor to undertake, render, and oversee all of the services under this Agreement. Upon written notice by the Contractor and approval by the

Authority, which will not be unreasonably withheld, the Contractor may substitute this person with another person, who may possess similar qualifications and experience for this position.

**6 CHANGES**

Authority may, at any time, by written order, make changes within the Scope of Work and services described in this Agreement. If such changes cause an increase in the budgeted cost of or the time required for performance of the agreed upon work, an equitable adjustment as mutually agreed shall be made in the limit on compensation as set forth in Section 3. In the event that the Contractor encounters any unanticipated conditions or contingencies that may affect the scope of work or services, schedule or the amount of compensation specified herein, Contractor shall so advise Authority immediately upon notice of such condition or contingency. The written notice shall explain the circumstances giving rise to the unforeseen condition or contingency and shall set forth the proposed adjustment in schedule or compensation. This notice shall be given to the Authority prior to the time that Contractor performs work or services related to any proposed adjustment. The pertinent changes shall be expressed in a written supplement to this Agreement prior to implementation of such changes.

**7. CONTRACTOR'S STATUS**

Contractor is an independent contractor and not an employee or agent of Authority and has no Authority to contract or enter into any other agreement in the name of Authority. Contractor has, and hereby retains, full control over the employment, direction, compensation and discharge of all persons employed by Contractor who are assisting in the performance of services under this Agreement. Contractor shall be fully responsible for all matters relating to the payment of its employees, including compliance with social security, withholding tax and all other laws and regulations governing such matters. Contractor shall be responsible for its own acts and those of its agents and employees during the term of this Agreement.

**8. INDEMNIFICATION**

To the maximum extent permitted by law, Contractor shall defend, indemnify and hold harmless Authority, its directors, officers, agents and employees from all claims, demands, suits, loss, damages, injury and liability, direct or indirect (including any and all costs and expenses in connection therewith) (collectively "Liability"), that arise out of, pertain to, or relate to the negligence, recklessness, or intentional misconduct of Contractor, its officers, agents, employees and subcontractors/subcontractors or any of them. This obligation shall not apply to Liability that arising from the sole negligence or willful misconduct of Authority or to defects in design furnished by Authority or that arise from the active negligence of Authority. Except as provided above, Contractor will indemnify and defend Authority notwithstanding any alleged or actual passive negligence of Authority which may have contributed to the Liability. In the event any aspect of the foregoing provision is found to be void or unenforceable, a court shall interpret this provision to give the maximum protection available to the Authority under

applicable law. This provision will survive termination or expiration of the Agreement.

**9. INSURANCE**

The insurance requirements specified in this section shall apply to Contractor and any subcontractors, suppliers, temporary workers, independent contractors, leased employees, or any other persons, firms or corporations that Contractor authorizes to work under this Agreement (hereinafter collectively referred to as "Agents"). Contractor and all Agents are required to procure and maintain at their sole cost and expense the insurance coverages subject to all of the requirements set forth below. Such insurance shall remain in full force and effect throughout the term of this Agreement. To the extent that any Agent does not procure and maintain such insurance coverage, Contractor shall be responsible for said coverage and assume any and all costs and expenses that may be incurred in securing said coverage or in fulfilling Contractor's indemnity obligation as to itself or any of its Agents in the absence of coverage. In the event Contractor or its Agents procure excess or umbrella coverage to maintain certain requirements outlined below, these policies shall also satisfy all specified endorsements and stipulations, including provisions that the Contractor's insurance be primary without any right of contribution from the Authority. Prior to beginning work under this contract, Contractor shall provide the Authority with satisfactory evidence of compliance with the insurance requirements of this section.

**A. Minimum Types and Scope of Insurance**

**1.) Workers' Compensation and Employers' Liability Insurance**

- a. Workers' Compensation with Statutory Limits, as required by Section 3700 et seq of the California Labor Code, or any subsequent amendments or successor acts thereto governing the liability of employers to their employees.
- b. Employers' Liability coverage with minimum limits of \$1 million.
- c. Such insurance shall include the following endorsement as further detailed in the Endorsements Section below:
  - Waiver of Subrogation.

**2.) Commercial General Liability Insurance**

Commercial General Liability insurance for bodily injury and property damage coverage with a combined single limit for bodily injury and property damage of at least \$1 million per occurrence or claim and a general aggregate limit of at least \$2 million. Such insurance shall cover all of Contractor's operations both at and away from the project site.

- a. This insurance shall include coverage for, but not be limited to:
- Premises and operations.
  - Products and completed operations.
  - Contractual liability.
  - Personal injury.
  - Advertising injury.
  - Explosion, collapse, and underground coverage
  - Broad form property damage.
- b. Such insurance shall include the following endorsements as further detailed in the Endorsements Section below:
- Additional Insured.
  - Cross Liability or Severability of Interests Clause.
  - Primary and Non-Contributory wording.
  - Waiver of Subrogation.

Products and completed operations insurance shall be maintained for three (3) years following termination of this Agreement.

### **3.) Business Automobile Liability Insurance**

Business Automobile Liability insurance providing bodily injury and property damage with a combined single limit of at least \$1 million per occurrence.

- a. This insurance shall include coverage for, but not be limited to:
- All Owned vehicles.
  - Non-owned vehicles.
  - Hired or rental vehicles.
- b. Such insurance shall include the following endorsements as further detailed in the Endorsements Section below:
- Additional Insured.
  - Primary and Non-Contributory wording.
  - Waiver of Subrogation.

## **ENDORSEMENTS**

### **A. Additional Insured**

The referenced policies and any Excess or Umbrella policies shall include as Additional Insureds the Livermore Amador Valley Transit Authority and its directors, officers, employees, volunteers and agents while acting in such capacity, and their successors or assignees, as they now, or as they may hereafter be constituted,

singly, jointly or severally.

**2.) Waiver of Subrogation**

The referenced policies and any Excess or Umbrella policies shall contain a waiver of subrogation in favor of the Livermore Amador Valley Transit Authority and its officers, directors, employees, volunteers and agents while acting in such capacity, and their successors and assignees, as they now, or as they may hereafter be constituted, singly, jointly or severally.

**3.) Primary Insurance**

The referenced policies and any Excess and Umbrella policies shall indicate that they are primary to any other insurance and the insurance company(ies) providing such policy(ies) shall be liable thereunder for the full amount of any loss or claim, up to and including the total limit of liability, without right of contribution from any of the insurance effected or which may be effected by the Livermore Amador Valley Transit Authority.

**4.) Severability of Interests or Cross Liability**

The referenced policies and any Excess or Umbrella policies shall contain either a Cross Liability endorsement or Severability of Interests Clause and stipulate that inclusion of the Livermore Amador Valley Transit Authority as an Additional Insured shall not in any way affect Authority's rights either as respects any claim, demand, suit or judgment made, brought or recovered against the Contractor. Said policy shall protect Contractor and the Livermore Amador Valley Transit Authority in the same manner as though a separate policy had been issued to each, but nothing in said policy shall operate to increase the insurance company's liability as set forth in its policy beyond the amount or amounts shown or to which the insurance company would have been liable if only one interest had been named as an insured.

**10. MAINTENANCE, AUDIT AND INSPECTION OF RECORDS**

All Contractor and subcontractors/subcontractors costs incurred in the performance of this Contract will be subject to audit. Contractor and its subcontractors/subcontractors shall permit LAVTA, or its authorized representatives to inspect, examine, make excerpts from, transcribe, and copy Contractor's books, work, documents, papers, materials, payrolls records, accounts, and any and all data relevant to the Agreement at any reasonable time, and to audit and verify statements, invoices or bills submitted by the Contractor pursuant to this Agreement. The Contractor shall also provide such assistance as may be required in the course of such audit. Contractor shall retain these records and make them available for inspection hereunder for a period of four (4) years after expiration or termination of the Agreement.



If, as a result of the audit, it is determined by LAVTA's auditor or staff that reimbursement of any costs including profit or fee under this Contract was in excess of that represented and relied upon during price negotiations or represented as a basis for payment, the Contractor agrees to reimburse LAVTA for those costs within sixty (60) days of written notification by LAVTA.

**11. HAZARDOUS MATERIALS**

Contractor shall bear full and exclusive responsibility for any release of hazardous or nonhazardous chemicals or substances during the course of performance of the Contract. Contractor shall immediately report any such release to LAVTA. It is the intent of the parties that Contractor shall be solely responsible in all circumstances for all claims and expenses associated with the response to, removal and remediation of the release, including, without limit, payment of any fines or penalties levied against LAVTA by any agency as a result of such release and shall hold harmless, indemnify and defend LAVTA from any claims or liability arising from such release, regardless of the absence of negligence or other malfeasance by Contractor, except to the extent such claims or liabilities were caused by the active negligence of LAVTA. The duties to defend and indemnify LAVTA survive termination of this contract.

For purposes of this Section only, the term "claims" shall include (i) all notices, orders, directives, administrative or judicial proceedings, fines, penalties, fees or charges imposed by any governmental agency with jurisdiction, and (ii) any claim, cause of action, or administrative or judicial proceeding brought against LAVTA, its directors, or employees, or for any loss, cost (including reasonable attorneys' fees), damage or liability sustained or suffered by any person or entity, including LAVTA.

**12. DATA TO BE FURNISHED BY AUTHORITY--CONFIDENTIALITY**

All data, reports, surveys, studies, drawings and any other documents and materials made available to Contractor by Authority for use by Contractor in the performance of its services under this Agreement shall be made available for information only and shall be returned to Authority at the completion or termination of this Agreement.

Any LAVTA materials to which the Contractor has access or materials prepared by the Contractor during the course of this Agreement ("confidential information") shall be held in confidence by the Contractor, who shall exercise all reasonable precautions to prevent the disclosure of confidential information to anyone except the officers, employees and agents of the Contractor as necessary to accomplish the rendition of services required by this Agreement.

Contractor shall not release any reports, information or promotional materials prepared in connection with this Agreement, whether deemed confidential or not, to any third party without the approval of the LAVTA.

**13. OWNERSHIP OF WORK**

- A. All communications and records originated, prepared, and in the process of being prepared, for the services to be performed by Contractor under this Agreement, including, but not limited to, findings, analyses, submittals, conclusions, opinions, engineering drawings, specifications, standards, process sheets, photographs, videos, manuals, technical reports and recommendations with respect to the subject matter of this Agreement and raw and underlying data of such materials, regardless of format or media, including software, reports and other documentation (all of the foregoing, collectively, the "Work Product"), shall be delivered to and become the property of LAVTA. LAVTA shall be entitled to access and to copy the Work Product during the progress of the Work. Any Work Product remaining in the hands of Contractor or in the hands of any subcontractor/subcontractor upon completion or termination of the work shall be immediately delivered to LAVTA and not later than within two (2) weeks of completion or termination of the Work. If any materials are lost, damaged or destroyed before final delivery to LAVTA, Contractor shall replace them at its own expense, and Contractor assumes all risk of loss, damage or destruction of or to such materials.
- B. Any specific knowledge of LAVTA proprietary information gained as a result of this Agreement shall be used exclusively to accomplish the Scope of Work outlined above and for no other purpose.
- C. Any and all rights of copyright to Work Product prepared under this Agreement are hereby assigned to LAVTA. Contractor agrees to execute any additional documents that may be necessary to evidence such assignment. Contractor agrees not to assert any rights at common law or equity and not to establish any claim to statutory copyright in such Work Product. Except for its own internal use, Contractor shall not publish or reproduce such Work Product in whole or in part, or in any manner or form, nor authorize others to do so, without the written consent of LAVTA
- D. Notwithstanding anything herein to the contrary, LAVTA acknowledges that as part of Contractor's provision of work hereunder, Contractor may utilize proprietary works of authorship including, without limitation, software, methodologies, tools, specifications, drawings, sketches, models, samples, records and documentation, as well as copyrights, trademarks, service marks, ideas, concepts, know-how, techniques, knowledge or data, that have been originated or developed by Contractor or by third parties under Agreement to, or which have been purchased by, Contractor (all of the foregoing, collectively, "Contractor's Information"). LAVTA agrees that Contractor's Information is and shall remain the sole property of Contractor or such third party. Contractor agrees that LAVTA shall be entitled to use Contractor's Information in connection with this Agreement, and shall grant to LAVTA a perpetual, royalty-free, irrevocable, worldwide, non-exclusive license to use all Contractor's Information and to create and use derivative works of Contractor's Information in connection with this Agreement.

- E. Contractor represents and warrants that it has or will have all appropriate licenses, agreements and/or ownership pertaining to all intellectual property, including but not limited to patents and copyrights, used in connection with the performance of its obligations under this Agreement. Contractor further represents and warrants that it will have all necessary rights to patentable and copyrightable materials, equipment, devices or processes not furnished by LAVTA used on or incorporated in the work and assumes all risks arising from the use of such patentable and copyrightable materials, equipment, devices, or processes.
- F. Contractor shall indemnify, defend and hold harmless LAVTA, its directors, officers, agents and employees to the maximum extent permitted by law from and against any and all claims, liabilities, losses, damages or expenses (including attorneys' fees and related costs, whether or not litigation has commenced), whether direct or indirect, arising out of, relating to, or in connection with the ownership, possession or use of any materials, equipment, devices, or processes that are protected by intellectual property rights, including patent, copyright and trade secret. In case such materials, equipment, devices or processes are held to constitute an infringement and their use enjoined, Contractor, at Contractor's sole cost and expense, shall: (a) secure for LAVTA the right to continue using the materials, equipment, devices or processes by suspension of the injunction or by procuring a royalty-free license or licenses, or (b) replace such materials, equipment, devices, or processes with non-infringing materials, equipment, devices or processes that perform the same functions as the infringing item, or (c) modify them so that they become non-infringing or remove the enjoined materials, equipment, devices or processes and refund the sums paid therefore, without prejudice to any other rights of LAVTA. If the amount of time necessary to proceed with one of these options is deemed excessive by LAVTA, LAVTA may direct Contractor to select another option or risk default.

**14. TERMINATION**

LAVTA shall have the right to suspend or terminate this Agreement at any time by giving written notice to the Contractor. Upon receipt of such notice, the Contractor shall not commit itself to any further expenditure of time or resources.

If the Agreement is suspended or terminated for any reason other than a default by Contractor, LAVTA shall pay to Contractor all sums actually due and owing from LAVTA for all services performed and all expenses incurred up to the day written notice of effective date of suspension or termination is given, plus any costs LAVTA determines are reasonably and necessarily incurred by Contractor to effect such suspension or termination. If the Agreement is terminated for default, LAVTA shall remit final payment to Contractor in an amount to cover only those services performed and expenses incurred in full accordance with the terms and conditions of this Agreement up to the effective date of termination.

**15. CLAIMS OR DISPUTES**

The Contractor shall be solely responsible for providing timely written notice to LAVTA of any claims for additional compensation and/or time in accordance with the provisions of this Agreement. It is the LAVTA's intent to investigate and attempt to resolve any Contractor claims before the Contractor has performed any disputed work. Therefore, Contractor's failure to provide timely notice shall constitute a waiver of Contractor's claims for additional compensation and/or time.

The Contractor shall not be entitled to the payment of any additional compensation for any cause, including any act, or failure to act, by the LAVTA, or the failure or refusal to issue a modification, or the happening of any event, thing, or occurrence, unless it has given the LAVTA due written notice of a potential claim. The notice of a potential claim shall set forth the reasons for which the Contractor believes additional compensation may be due, the nature of the costs involved, and the amount of the potential claim.

If based on an act or failure to act by the LAVTA, such notice shall be given to the LAVTA prior to the time that the Contractor has started performance of the work giving rise to the potential claim for additional compensation. In all other cases, notice shall be given within 10 days after the happening of the event or occurrence giving rise to the potential claim.

If there is a dispute over any claim, the Contractor shall continue to work during the dispute resolution process in a diligent and timely manner as directed by the LAVTA, and shall be governed by all applicable provisions of this Agreement. The Contractor shall maintain cost records of all work which is the basis of any dispute.

If an agreement can be reached which resolves the Contractor's claim, the parties will execute a contract change to document the resolution of the claim. If the parties cannot reach an agreement with respect to the Contractor's claim, they may choose to pursue a dispute resolution process.

**16. CONFLICT OF INTEREST**

A. General

Depending on the nature of the work performed, a Contractor of LAVTA may be subject to the same conflict of interest prohibitions established by the Federal Transit Administration (FTA) and California law that govern LAVTA's employees and officials (Cal. Govt. Code Section 1090 et seq. and Cal. Govt. Code Section 87100 et seq.). During the proposal process or the term of the Agreement, Contractor and its employees may be required to disclose financial interests.

The Contractor warrants and represents that it presently has no interest and agrees that it will not acquire any interest that would present a conflict of interest under California Government Code §1090 et seq. or §87100 et seq. during the

performance of services under this Agreement. The Contractor further covenants that it will not knowingly employ any person having such an interest in the performance of this Agreement. Violation of this provision may result in this Agreement being deemed void and unenforceable or subject to termination.

Depending on the nature of the work performed, Contractor may be required to publicly disclose financial interests under LAVTA's Conflict of Interest Code. Upon receipt, the Contractor agrees to promptly submit a Statement of Economic Interest on the form provided by LAVTA.

No person previously in the position of director, officer, employee or agent of LAVTA may act as an agent or attorney for, or otherwise represent the Contractor, by making any formal or informal appearance, or any oral or written communication, before LAVTA, or any officer or employee of LAVTA, for a period of twelve months after leaving office or employment with LAVTA if the appearance or communication is made for the purpose of influencing any action involving the issuance, amendment, award or revocation of a permit, license, grant, or contract.

No officer or employee of LAVTA during his or her tenure or for one year after that tenure shall have any interest, direct or indirect, in this Agreement or the proceeds under this Agreement.

B. Organizational Conflicts of Interest

Contractor shall take all reasonable measures to preclude the existence or development of an organizational conflict of interest in connection with work performed under this Agreement and other solicitations. An organizational conflict of interest occurs when, due to other activities, relationships, or contracts: a firm or person is unable, or potentially unable, to render impartial assistance or advice to LAVTA; a firm or person's objectivity in performing the contract work is or might be impaired; or a firm or person has an unfair competitive advantage in proposing for award of a contract as a result of information gained in performance of this or some other Agreement.

Contractor shall not engage the services of any Subcontractor or independent Contractor on any work related to this Agreement if the Subcontractor or independent Contractor, or any employee of the Subcontractor or independent Contractor, has an actual or apparent organizational conflict of interest related to work or services contemplated under this Agreement.

If at any time during the term of this Agreement Contractor becomes aware of an organizational conflict of interest in connection with the work performed hereunder, Contractor immediately shall provide LAVTA with written notice of the facts and circumstances giving rise to this organizational conflict of interest. Contractor's written notice will also propose alternatives for addressing or eliminating the organizational conflict of interest.

If at any time during the term of this Agreement, LAVTA becomes aware of an organizational conflict of interest in connection with Contractor's performance of the work hereunder, LAVTA shall similarly notify Contractor.

In the event a conflict is presented, whether disclosed by Contractor or discovered by LAVTA, LAVTA will consider the conflict presented and any alternatives proposed and meet with the Contractor to determine an appropriate course of action. LAVTA's determination as to the manner in which to address the conflict shall be final.

During the term of this Agreement, Contractor must maintain lists of its employees, and the Subcontractors and independent Contractors used and their employees. Contractor must provide this information to LAVTA upon request. However, submittal of such lists does not relieve the Contractor of its obligation to assure that no organizational conflicts of interest exist. Contractor shall retain this record for five (5) years after LAVTA makes final payment under this Agreement. Such lists may be published as part of future LAVTA solicitations.

Contractor shall maintain written policies prohibiting organizational conflicts of interest and shall ensure that its employees are fully familiar with these policies. Contractor shall monitor and enforce these policies and shall require any subcontractors and affiliates to maintain, monitor and enforce policies prohibiting organizational conflicts of interest.

Failure to comply with this section may subject the Contractor to damages incurred by LAVTA in addressing organizational conflicts that arise out of work performed by Contractor, or to termination of this Agreement for breach

## **17. LABOR CODE REQUIREMENTS**

The work performed under this Contract is subject to Public Works requirements. To the extent applicable, Contractors shall comply with California Labor Code and Prevailing Wage Laws. General Wage Determinations issued by the Director of Industrial Relations as applicable to the Livermore Amador Valley Transit Authority are available for inspection at the offices of the Authority.

Contractor and each subcontractor shall submit electronic certified payroll records to the California Labor Commissioner in the manner and format set forth in California Labor Code section 1771.4.

The Contractor's attention is directed to the following provisions of Labor Code Section 1776. The Contractor shall be responsible for the compliance with these provisions by its subcontractors:

- A. Hours of Labor. Eight hours labor constitutes a legal day's work. The Contractor or subcontractor shall, as a penalty to the state or political subdivision on whose behalf the Contract is made or awarded, forfeit \$25 for each worker employed in the performance of the Contract by the Contractor or subcontractor under him for each calendar day during which

the worker is required or permitted to work more than 8 hours in any one calendar day and 40 hours in any one calendar week in violation of the provisions of the Labor Code Section 1813. Notwithstanding the provisions of Sections 1810 to 1814, inclusive, of the Labor Code and notwithstanding any stipulation inserted in any contract pursuant to the requirements of these sections, work performed by employees of the Contractor or subcontractor in excess of 8 hours per day and 40 hours during any one week shall be permitted upon compensation for all hours worked in excess of 8 hours per day and in excess of 40 hours during any one week at not less than 1½ times the basic rate of pay, as provided for in Section 1815. In addition, contractor/ subcontractor may be required to pay double the basic rate of pay for all hours worked in excess of 12 hours in any workday and under other circumstances. (See California Code of Regulations sections 16100(c)(6), 16200(a)(3)(F) and applicable prevailing wage determinations.)

- B. Prevailing Wages. The Contractor and any subcontractor shall comply with Labor Code Sections 1774 and 1775. Pursuant to Section 1775, the Contractor and any subcontractor shall, as a penalty, forfeit to the state or political subdivision not more than \$50 for each calendar day, or portion thereof, for each worker paid less than the prevailing rate as determined by the Director of Industrial Relations for the work or craft in which the worker is employed under the contract. The amount of this forfeiture shall be determined by the Labor Commissioner and shall be based on consideration of whether the failure to pay the correct rate of per diem wages was due to the Contractor's good-faith mistake, and on the previous record of the Contractor or subcontractor in meeting their respective prevailing wage obligations. In addition to said penalty, the difference between such prevailing wage rates and the amount paid to each worker for each calendar day or portion thereof for which each worker was paid less than the prevailing wage rate shall be paid to each worker by the Contractor or subcontractor.

If a worker employed by a subcontractor on a public works project is not paid at least the general prevailing per diem wages by the subcontractor, the Contractor shall not be liable for the penalties described above unless the Contractor had knowledge of that failure of the subcontractor to pay the specified prevailing rate of wages to those workers or unless the Contractor fails to comply with all of the following requirements:

The contract executed between the Contractor and the subcontractor for the performance of work on the public works project shall include a copy of the provisions of Sections 1771, 1775, 1776, 1777.5, 1813, and 1815 of the Labor Code.

The Contractor shall monitor the payment of the specified general prevailing rate of per diem wages by the subcontractor to the employees, by periodic review of the certified payroll records of the subcontractor.

Upon becoming aware of the subcontractor's failure to pay at least the specified prevailing rate of wages to the subcontractor's workers, the Contractor shall diligently take corrective action to halt or rectify the failure, including, but not limited to, retaining sufficient funds due the subcontractor for work performed on the public work project.

Prior to making final payment to the subcontractor for work performed on the public works project, the Contractor shall obtain an affidavit signed under penalty of perjury from the subcontractor that the subcontractor has paid at least the specified general prevailing rate of per diem wages to the subcontractor's employees on the public works project and any amount due pursuant to 1813 of the Labor Code.

Pursuant to Section 1775 of the Labor Code, the Division of Labor Standards Enforcement shall notify the Contractor on a public works project within 15 days of the receipt by the Division of Labor Standards Enforcement of a complaint of the failure of a subcontractor on that public works project to pay workers at least the general prevailing rate per diem wages.

Pursuant to the provisions of Section 1773 of the Labor Code, the Owner has obtained the general prevailing rate of wages applicable to categories of workers the Owner anticipates will be utilized for this project for straight time, overtime, Saturday, Sunday and holiday work. The holiday wage rate listed shall be applicable to all holidays recognized in the collective bargaining agreement of the particular craft, classification or type of workmen concerned, of if no collective bargaining agreement applies, those holidays identified in Government Code Section 6700. Prevailing wage rates for this project are available at the offices of the Authority. In the event that the Contractor intends to utilize categories of workers different from, or in addition to, those anticipated by the Owner, it shall be Contractor's responsibility to bring such categories of workers to the Owner's attention immediately, and to obtain the appropriate wage rate from the Department of Industrial Relations (with the Owner's assistance if necessary). (See Title 8 California Code of Regulations Section 16202.)

The Contractor shall post general prevailing wage rates at a prominent place at the site of the work.

Pursuant to Labor Code Section 1773.6 and Title 8 California Code of Regulations Section 16204, changes in general prevailing wage determinations shall apply to the project only if issued by the Director of Industrial Relations prior to the Owner's bid issuance date.

The Authority will not recognize any claim for additional compensation because of the payment by the Contractor of any wage rate in excess of the prevailing wage rate set forth in the Contract. The possibility of wage increases is one of the elements to be considered by the Contractor in determining its bid, and will not under any circumstances be considered



as the basis of a claim against the Authority on the Contract.

- C. Payroll Records. The Contractor's attention is directed to the following provisions of Labor Code Section 1776. The Contractor shall be responsible for compliance with these provisions by his subcontractors.
1. The Contractor and each subcontractor shall keep accurate payroll records, showing the name, address, social security number, work classification, straight time and overtime hours worked each day and week, and the actual per diem wages paid to each journeyman, apprentice, worker, or other employee employed by him or her in connection with the public work.
  2. The payroll records enumerated under subdivision (1) shall be certified and shall be available for inspection at all reasonable hours at the principal office of the Contractor on the following basis:
    - (a) A certified copy of an employee's payroll record shall be made available for inspection or furnished to such employee or his or her authorized representative on request.
    - (b) A certified copy of all payroll records enumerated in subdivision (1) shall be made available for inspection or furnished upon request to the Division of Labor Standards Enforcement and the Division of Apprenticeship Standards of the Department of Industrial Relations.
    - (c.) A certified copy of all payroll records enumerated in subdivision (1) shall be furnished to the Authority's Labor Compliance Officer at the time the Contractor invoices for authorized work.

A certified copy of all payroll records enumerated in subdivision (1) shall be made available upon request to the public for inspection or copies thereof made; provided, however, that a request by the public shall be made through either the Owner, the Division of Apprenticeship Standards or the Division of Labor Standards Enforcement. If the requested payroll records have not been provided pursuant to paragraph (b), the requesting party shall, prior to being provided the records, reimburse the costs of preparation by the Contractor, subcontractor and the entity through which the request was made. The public shall not be given access to such records at the principal office of the Contractor.
  3. Contractor and each subcontractor shall file a certified copy of the records enumerated in subdivision (1) with the entity that requests

such records within 10 days after receipt of a written request.

4. Any copy of records made available for inspection as copies and furnished upon request to the public or the Owner, the Division of Apprenticeship Standards or the Division of Labor Standards Enforcement shall be redacted in such a manner as to prevent disclosure of an individual's name, address and social security number. The name and address of the Contractor shall not be redacted.
  5. The Contractor shall inform the Owner of the location of records enumerated under subdivision (1), including the street address, city and county, and shall, within five working days, provide a notice of a change of location and address.
  6. The Contractor shall have 10 days in which to comply subsequent to receipt of written notice requesting the records enumerated in subdivision (1). Failure to comply after such 10-day period will subject Contractor to a penalty to the state or the political subdivision on whose behalf the contract is made or awarded, in the amount of \$25 for each calendar day, or portion thereof, for each worker, until strict compliance is effectuated. Upon the request of the Division of Apprenticeship Standards or the Division of Labor Standards Enforcement, such penalties shall be withheld from progress payments then due.
  7. The penalties specified in subdivision (7) above for noncompliance with the provisions of said Section 1776 may be withheld from any monies due or which may become due to the Contractor.
  8. The Contractor and each subcontractor shall preserve their payroll records for a period of 3 years from the date of completion of the Contract.
- D. Apprentices. The Contractor shall fully comply with the requirements of Sections 1777.5 and 1777.6 of the California Labor Code and the regulations of the California Apprenticeship Council. In accordance with Section 1777.5, the Contractor shall secure the necessary certificates and shall contribute to the apprenticeship fund or funds, as provided for therein. The Contractor shall require each subcontractor who will perform work or labor or render service to the Contractor in or about the construction of the work to comply fully with Sections 1777.5 and 1777.6 of the Labor Code. Information relative to apprenticeship standards, wage schedules and other requirements may be obtained from the State Division of Apprenticeship Standards and its branch offices.
- E. For information regarding labor classifications and rate determinations, please visit the California Department of Industrial Relations website at <http://www.dir.ca.gov>. Bidders may also contact the Authority's

Procurement Officer with questions or submit their questions in writing pursuant to Instructions to Proposers, Part 6.

- F. Workers' Compensation. In accordance with the provisions of Labor Code Section 3700, the Contractor will be required to secure the payment of compensation to its employees. The Contractor shall sign and file with the Contract Officer the following certification prior to performing the work of the contract:

"I am aware of the provisions of Section 3700 of the Labor Code which requires every employer to be insured against liability for workers' compensation or to undertake self-insurance in accordance with the provisions of that code, and I will comply with such provisions before commencing the performance."

- G. Prohibition Against Debarred Contractors. Contractors are prohibited from performing work on a public works project with a subcontractor who is ineligible to perform work on the public works project pursuant to Section 1777.1 or 1777.7 of the Labor Code.

- H. Trench Safety. For all contracts over \$25,000, excavation for any trench 5 feet or more in depth shall not begin until the Contractor has received approval from LAVTA, of the Contractor's detailed plan for worker protection from the hazards of caving ground during the excavation of such trench. Such plan shall be submitted at least 5 days before the Contractor intends to begin excavation for the trench and shall show the details of the design of shoring, bracing, sloping or other provisions to be made for worker protection during such excavation. No such plan shall allow the use of shoring, sloping or a protective system less effective than that required by the Construction Safety Orders of the Division of Industrial Safety; and if such plan varies from the shoring system standards established by the Construction Safety Orders, the plan shall be prepared and signed by an engineer who is registered as a Civil or Structural Engineer in the State of California. Attention is directed to the provisions of Section 6705 of the Labor Code concerning trench excavation safety plans.

**18. WARRANTY OF SERVICES**

- A. Contractor warrants that its professional services will be performed in accordance with the professional standards of practices of comparable firms at the time the services are rendered. In addition, Contractor shall provide such specific warranties as may be set forth in the individual Task Orders as agreed upon by the parties.
- B. In the event that any services provided by the Contractor hereunder are deficient because of Contractor's or subcontractors failure to perform said services in accordance with the warranty standards set forth above, LAVTA shall report such deficiencies in writing to the Contractor within a reasonable time. LAVTA thereafter shall have:

1. The right to have the Contractor re-perform such services at the Contractor's expense; or
2. The right to have such services done by others and the costs thereof charged to and collected from the Contractor if within thirty days after written notice to the Contractor requiring such re-performance, Contractor fails to give satisfactory evidence to LAVTA that it has undertaken said re-performance.
3. The right to terminate the Agreement for default.

**19. SUBCONTRACTS**

Contractor shall not subcontract all or any portion of its services under this Agreement without the prior written approval of the Authority, and any attempt thereat shall be void and unenforceable. In the event that Contractor enters into one or more subcontracts pursuant to this article, it is understood and agreed that the participating subcontractors shall be solely and directly responsible to Contractor, and Authority shall have no obligation to them.

**20. ASSIGNMENT OF AGREEMENT**

Contractor shall not assign this Agreement or any part thereof without prior express written consent of Authority, and any attempt thereat shall be void and unenforceable.

**21. FEDERAL CONTRACT PROVISIONS**

This Contract may be subject to financial assistance from the U.S. Department of Transportation, Federal Transit Administration (FTA). The following provisions therefore apply:

**A. FLY AMERICA REQUIREMENTS.**

The Contractor agrees to comply with 49 U.S.C. 40118 (the "Fly America Act") in accordance with the General Services Administration's regulations at 41 CFR Part 301 - 10, which provide that recipients and subrecipients of Federal funds and their consultants are required to use U.S. flag air carriers for U.S. Government-financed international air travel and transportation of their personal effects or property to the extent such service is available, unless travel by foreign air carrier is a matter of necessity as defined by the Fly America Act. The Contractor shall submit, if a foreign air carrier was used, an appropriate certification or memorandum adequately explaining why service by a U.S. flag air carrier was not available or why it was necessary to use a foreign air carrier and shall, in any event, provide a certificate of compliance with the Fly America requirements, if used. The Contractor agrees to include the requirements of this Section in all subcontracts that may involve international air transportation.

**B. CARGO PREFERENCE REQUIREMENTS.**

The Contractor agrees: (a) to use privately owned United States Flag commercial vessels to ship at least 50 percent of the gross tonnage (computed separately for dry bulk carriers, dry cargo liners, and tankers) involved, whenever shipping any equipment, material, or commodities pursuant to this Contract by ocean vessels to the extent such vessels are available at fair and reasonable rates for United States-flag commercial vessels; (b) to furnish within 20 working days following the date of loading for shipments originating within the United States or within 30 working days following the date of loading for shipments originating outside the United States, a legible copy of a rated, "on-board" commercial ocean bill-of-lading in English for each shipment of cargo described in the preceding paragraph to the Division of National Cargo, Office of Market Development, Maritime Administration, Washington, DC 20590 and to the Authority (through the Contractor in the case of a subcontractor's bill-of-lading); and (c) to include these requirements in all subcontracts issued pursuant to this Contract when the subcontract may involve the transport of equipment, Material, or commodities by ocean vessel.

**C. ENERGY CONSERVATION.**

The Contractor agrees to comply with mandatory standards and policies relating to energy efficiency which are contained in the state energy conservation plan issued in compliance with the Federal Energy Policy and Conservation Act, 42 U.S.C. §§ 6321 et seq.

**D. RECYCLED PRODUCTS.**

The Consultant agrees to provide a preference for those products and services that conserve natural resources, protect the environment, and are energy efficient by complying with and facilitating compliance with Section 6002 of the Resource Conservation and Recovery Act, as amended, 42 U.S.C. § 6962, and U.S. Environmental Protection Agency (U.S. EPA), "Comprehensive Procurement Guideline for Products Containing Recovered Materials," 40 C.F.R. part 247.

**E. CLEAN WATER AND AIR REQUIREMENTS.**

The Contractor agrees to comply with all applicable standards, orders or regulations issued pursuant to the Federal Water Pollution Control Act, as amended, 33 U.S.C. 1251 et seq., and the Clean Air Act, as amended, 42 U.S.C. 7401 et seq. The Contractor agrees to report each violation to the Authority and understands and agrees that the Authority will, in turn, report each violation as required to assure notification to the FTA and the appropriate EPA regional office.

The Contractor also agrees to include these requirements in each subcontract exceeding \$150,000 financed in part or in whole with federal assistance provided by the FTA.

**F. LOBBYING.**

Contractor shall file the certification required by 49 CFR Part 20, "New Restrictions on Lobbying." Contractor shall certify that it will not and has not used Federally appropriated funds to pay any person or organization for influencing or attempting to

influence an officer or employee of any agency, a member of Congress, officer or employee of Congress, or an employee of a member of Congress in connection with obtaining any Federal contract, grant or any other award covered by 31 U.S.C. 1352. Contractor shall also disclose the name of any registrant under the Lobbying Disclosure Act of 1995 who has made lobbying contacts on its behalf with non-Federal funds with respect to that Federal contract, grant or award covered by 31 U.S.C. 1352. Such disclosures shall be forwarded to the Authority. Contractor shall ensure that all of its subcontractors/subconsultants under this Contract shall certify the same. The Authority is responsible for keeping the certification of the Contractor, who is in turn responsible for keeping the certification forms of subcontractors/subconsultants.

The Bidder shall complete Standard Form SF-LLL, "Disclosure of Lobbying Activities," which is included with the Bid Documents, including instructions for completion.

#### **G. ACCESS TO RECORDS AND REPORTS.**

Contractor shall provide all authorized representatives of the Authority, the FTA Administrator, the State Auditor and the Comptroller General of the United States access to any books, documents, papers and records of the Contractor which are directly pertinent to this Contract for the purposes of making audits, copies, examinations, excerpts and transcriptions. Contractor also agrees to maintain all books, records, accounts and reports required under this Contract for a period of not less than three years after the date of termination or expiration of this Contract, except in the event of litigation or settlement of claims arising from the performance of this Contract, in which case Contractor agrees to maintain the same until the Authority, the FTA Administrator, the Comptroller General, or any of their duly authorized representatives, have disposed of all such litigation, appeals, claims or exceptions related thereto.

#### **H. FEDERAL CHANGES.**

Contractor shall at all times comply with all applicable FTA regulations, policies, procedures and directives, including without limitation those listed directly or by reference in the Agreement (Form FTA MA (23) dated October 1, 2016) between the Authority and the FTA, as they may be amended or promulgated from time to time during the term of this Contract. Contractor's failure to so comply shall constitute a material breach of this Contract.

#### **I. NO GOVERNMENT OBLIGATION TO THIRD PARTIES.**

The Authority and Contractor acknowledge and agree that, notwithstanding any concurrence by the Federal Government in or approval of the solicitation or award of the underlying contract, absent the express written consent by the Federal Government, the Federal Government is not a party to this Contract and shall not be subject to any obligations or liabilities to the Authority, Contractor, or any other party (whether or not a party to that contract) pertaining to any matter resulting from the underlying contract.

The Contractor agrees to include the above clause in each subcontract financed in whole or in part with Federal assistance provided by FTA. It is further agreed that the clause shall not be modified, except to identify the subcontractor/subconsultant who will be subject to its provisions.

**J. PROGRAM FRAUD AND FALSE OR FRAUDULENT STATEMENTS AND RELATED ACTS.**

The Contractor acknowledges that the provisions of the Program Fraud Civil Remedies Act of 1986, as amended, 31 U.S.C. § 3801 et seq. and U.S. DOT regulations, "Program Fraud Civil Remedies," 49 CFR Part 31, apply to its actions pertaining to this Project. Upon execution of the underlying contract, the Contractor certifies or affirms the truthfulness and accuracy of any statement it has made, it makes, it may make, or causes to be made, pertaining to the underlying contract or the FTA assisted project for which this Contract work is being performed. In addition to other penalties that may be applicable, the Contractor further acknowledges that if it makes, or causes to be made, a false, fictitious, or fraudulent claim, statement, submission, or certification, the Federal Government reserves the right to impose the penalties of the Program Fraud Civil Remedies Act of 1986 on the Contractor to the extent the Federal Government deems appropriate.

The Contractor also acknowledges that if it makes, or causes to be made, a false, fictitious, or fraudulent claim, statement, submission, or certification to the Federal Government under a contract connected with a project that is financed in whole or in part with Federal assistance originally awarded by FTA under the authority of 49 U.S.C. § 5307, the Government reserves the right to impose the penalties of 18 U.S.C. § 1001 and 49 U.S.C. § 5307 on the Contractor, to the extent the Federal Government deems appropriate.

The Contractor agrees to include the above two clauses in each subcontract financed in whole or in part with Federal assistance provided by FTA. It is further agreed that the clauses shall not be modified, except to identify the subcontractor/subconsultant who will be subject to the provisions.

**K. GOVERNMENT-WIDE DEBARMENT AND SUSPENSION.**

This contract is a covered transaction for purposes of 2 CFR Parts 180. As such, the Contractor is required to verify that none of the Contractor, its principals, as defined at 2 CFR 180.995, or affiliates, as defined at 2 CFR 180.905, are excluded or disqualified as defined at 2 CFR 180.940 and 180.935.

The Contractor is required to comply with 2 CFR Part 180, Subpart C and must include the requirement to comply with 2 CFR Part 180, Subpart C in any lower tier covered transaction it enters into.

By signing and submitting its bid or proposal, Bidder certifies as follows:

The certification in this clause is a material representation of fact relied upon by the Authority. If it is later determined that the proposer knowingly rendered an erroneous certification, in addition to remedies available to the Authority, the Federal Government may pursue available remedies, including but not limited to suspension and/or debarment. The bidder or proposer agrees to comply with the requirements of 2 CFR Part 180, Subpart C while this offer is valid and throughout the period of any contract that may arise from this offer. The bidder or proposer further agrees to include a provision requiring such compliance in its lower tier covered transactions.

**L. CIVIL RIGHTS REQUIREMENTS.**

The following requirements apply to the underlying contract:

1. Nondiscrimination - In accordance with Title VI of the Civil Rights Act, as amended, 42 U.S.C. § 2000d, section 303 of the Age Discrimination Act of 1975, as amended, 42 U.S.C. § 6102, section 202 of the Americans with Disabilities Act of 1990, 42 U.S.C. § 12132, and Federal transit law at 49 U.S.C. § 5332, the Contractor agrees that it will not discriminate against any employee or applicant for employment because of race, color, creed, national origin, sex, age, or disability. In addition, the Contractor agrees to comply with applicable Federal implementing regulations and other implementing requirements FTA may issue.

2. Equal Employment Opportunity - The following equal employment opportunity requirements apply to the underlying contract:

(a) Race, Color, Creed, National Origin, Sex - In accordance with Title VII of the Civil Rights Act, as amended, 42 U.S.C. § 2000e, and Federal transit laws at 49 U.S.C. § 5332, the Contractor agrees to comply with all applicable equal employment opportunity requirements of U.S. Department of Labor (U.S. DOL) regulations, "Office of Federal Contract Compliance Programs, Equal Employment Opportunity, Department of Labor," 41 CFR Parts 60 et seq., (which implement Executive Order No. 11246, "Equal Employment Opportunity," as amended by Executive Order No. 11375, "Amending Executive Order 11246 Relating to Equal Employment Opportunity," 42 U.S.C. § 2000e note), and with any applicable Federal statutes, executive orders, regulations, and Federal policies that may in the future affect construction activities undertaken in the course of the Project. The Contractor agrees to take affirmative action to ensure that applicants are employed, and that employees are treated during employment, without regard to their race, color, creed, national origin, sex, or age. Such action shall include, but not be limited to, the following: employment, upgrading, demotion or transfer, recruitment or recruitment advertising, layoff or termination; rates of pay or other forms of compensation; and selection for training, including apprenticeship. In addition, the Contractor agrees to comply with any implementing requirements FTA may issue.

(b) Age - In accordance with section 4 of the Age Discrimination in Employment Act of 1967, as amended, 29 U.S.C. § 623 and Federal transit law at 49 U.S.C. § 5332, the Contractor agrees to refrain from discrimination against present and prospective employees for reason of age. In addition, the Contractor agrees to comply with any implementing requirements FTA may issue.

(c) Disabilities - In accordance with section 102 of the Americans with Disabilities Act, as amended, 42 U.S.C. § 12112, the Contractor agrees that it will comply with the requirements of U.S. Equal Employment Opportunity Commission, "Regulations to Implement the Equal Employment Provisions of the Americans with Disabilities Act," 29 CFR Part 1630, pertaining to employment of persons with disabilities. In addition, the Contractor agrees to comply with any implementing requirements FTA may issue.

3. The Contractor also agrees to include these requirements in each subcontract financed in whole or in part with Federal assistance provided by FTA, modified only if necessary to identify the affected parties.



**M. SAFE OPERATION OF MOTOR VEHICLES.**

The Consultant is encouraged to adopt and promote on-the-job seat belt use policies and programs for its employees and other personnel that operate company-owned vehicles, company-rented vehicles, or personally operated vehicles. The terms “company-owned” and “company-leased” refer to vehicles owned or leased either by the Consultant or the Authority. The Consultant agrees to adopt and enforce workplace safety policies to decrease crashes caused by distracted drivers, including policies to ban text messaging while using an electronic device supplied by an employer, and driving a vehicle the driver owns or rents, a vehicle Consultant owns, leases, or rents, or a privately-owned vehicle when on official business in connection with the work performed under this agreement.

**N. DAVIS-BACON ACT REQUIREMENTS.**

A. Minimum wages

1. All laborers and mechanics employed or working upon the site of any qualifying construction work under the Contract (or under the United States Housing Act of 1937 or under the Housing Act of 1949 in the construction or development of the project), will be paid unconditionally and not less often than once a week, and without subsequent deduction or rebate on any account (except such payroll deductions as are permitted by regulations issued by the Secretary of Labor under the Copeland Act (29 CFR Part 3)), the full amount of wages and bona fide fringe benefits (or cash equivalents thereof) due at time of payment computed at rates not less than those contained in the wage determination of the Secretary of Labor which is attached hereto and made a part hereof, regardless of any contractual relationship which may be alleged to exist between the Contractor and such laborers and mechanics.

Contributions made or costs reasonably anticipated for bona fide fringe benefits under section I (b)(2) of the Davis-Bacon Act on behalf of laborers or mechanics are considered wages paid to such laborers or mechanics, subject to the provisions of Subsection (A)(4) of this Section; also, regular contributions made or costs incurred for more than a weekly period (but not less often than quarterly) under plans, funds, or programs which cover the particular weekly period are deemed to be constructively made or incurred during such weekly period. Such laborers and mechanics shall be paid the appropriate wage rate and fringe benefits on the wage determination for the classification of work actually performed, without regard to skill, except as provided in 29 CFR Part 5.5(a)(4). Laborers or mechanics performing work in more than one classification may be compensated at the rate specified for each classification for the time actually worked therein, provided that the employer's payroll records accurately set forth the time spent in each classification in which such work is performed. The wage determination (including any additional classification and wage rates conformed under paragraph (A)(4) of this section) and the Davis-Bacon poster (WH- 1321) shall be posted at all times by the Contractor and its subcontractors at the site of the work in a prominent and accessible place where it can be easily seen by the workers.

2. Whenever the minimum wage rate prescribed in the Contract for a class of laborers or mechanics includes a fringe benefit which is not expressed as an hourly rate,

the Contractor shall either pay the benefit as stated in the wage determination or shall pay another bona fide fringe benefit or an hourly cash equivalent thereof.

3. If the Contractor does not make payments to a trustee or other third person, the Contractor may consider as part of the wages of any laborer or mechanic the amount of any costs reasonably anticipated in providing bona fide fringe benefits under a plan or program, provided that the Secretary of Labor has found, upon the written request of the Contractor, that the applicable standards of the Davis-Bacon Act have been met. The Secretary of Labor may require the Contractor to set aside in a separate account assets for the meeting of obligations under the plan or program.

4. (a) The contracting officer shall require that any class of laborers or mechanics which is not listed in the wage determination and which is to be employed under the Contract shall be classified in conformance with the wage determination. The contracting officer shall approve an additional classification and wage rate and fringe benefits therefor only when the following criteria have been met:

(i) The work to be performed by the classification requested is not performed by a classification in the wage determination; and

(ii) The classification is utilized in the area by the construction industry; and

(iii) The proposed wage rate, including any bona fide fringe benefits, bears a reasonable relationship to the wage rates contained in the wage determination.

(b) If the Contractor and the laborers and mechanics to be employed in the classification (if known), or their representatives, and the contracting officer agree on the classification and wage rate (including the amount designated for fringe benefits where appropriate), a report of the action taken shall be sent by the contracting officer to the Administrator of the Wage and Hour Division, Employment Standards Administration, Washington, DC 20210. The Administrator, or an authorized representative, will approve, modify, or disapprove every additional classification action within 30 days of receipt and so advise the contracting officer or will notify the contracting officer within the 30-day period that additional time is necessary.

(c) In the event the Contractor, the laborers or mechanics to be employed in the classification, or their representatives, and the contracting officer do not agree on the proposed classification and wage rate (including the amount designated for fringe benefits, where appropriate), the contracting officer shall refer the questions, including the views of all interested parties and the recommendation of the contracting officer, to the Administrator for determination. The Administrator, or an authorized representative, will issue a determination with 30 days of receipt and so advise the contracting officer or will notify the contracting officer within the 30-day period that additional time is necessary.

(d) The wage rate (including fringe benefits where appropriate) determined pursuant to Subsections (A)(4)(b) or (c) of this Section, shall be paid to all workers performing work in the classification under this Contract from the first day on which work is performed in the classification.

B. Withholding

The Authority shall upon its own action or upon written request of an authorized representative of the Department of Labor withhold or cause to be withheld from the Contractor under this Contract or any other Federal contract with the Contractor, or any other Federally-assisted contract subject to Davis-Bacon prevailing wage requirements which is held by the Contractor, so much of the accrued payments or advances as may be considered necessary to pay laborers and mechanics, including apprentices, trainees, and helpers, employed by the Contractor or any subcontractor the full amount of wages required by the Contract. In the event of failure to pay any laborer or mechanic, including any apprentice, trainee, or helper, employed or working on the site of the work (or under the United States Housing Act of 1937 or under the Housing Act of 1949 in the construction or development of the project), all or part of the wages required by the Contract, the Authority may, after written notice to the Contractor, sponsor, applicant, or owner, take such action as may be necessary to cause the suspension of any further payment, advance, or guarantee of funds until such violations have ceased.

C. Payrolls and basic records

1. Payrolls and basic records relating thereto shall be maintained by the Contractor during the course of the work and preserved for a period of three years thereafter for all laborers and mechanics working at the site of the work (or under the United States Housing Act of 1937, or under the Housing Act of 1949, in the construction or development of the project). Such records shall contain the name, address, and social security number of each such worker, his or her correct classification, hourly rates of wages paid (including rates of contributions or costs anticipated for bona fide fringe benefits or cash equivalents thereof of the types described in section 1(b)(2)(B) of the Davis-Bacon Act), daily and weekly number of hours worked, deductions made and actual wages paid. Whenever the Secretary of Labor has found under 29 CFR 5.5(a)(1)(iv) that the wages of any laborer or mechanic include the amount of any costs reasonably anticipated in providing benefits under a plan or program described in section 1(b)(2)(B) of the Davis-Bacon Act, the Contractor shall maintain records which show that the commitment to provide such benefits is enforceable, that the plan or program is financially responsible, and that the plan or program has been communicated in writing to the laborers or mechanics affected, and records which show the costs anticipated or the actual cost incurred in providing such benefits. Contractors employing apprentices or trainees under approved programs shall maintain written evidence of the registration of apprenticeship programs and certification of trainee programs, the registration of the apprentices and trainees, and the ratios and wage rates prescribed in the applicable programs.

2. (a) The Contractor shall submit weekly for each week in which any contract work is performed a copy of all payrolls to the Authority for transmission to the Federal Transit Administration. The payrolls submitted shall set out accurately and completely all of the information required to be maintained under 29 CFR 5.5(a)(3)(i), except that full social security numbers and home addresses shall not be included on weekly transmittals. Instead the payrolls shall only need to include an individually identifying number for each employee (e.g., the last four digits of the employee's social security number). This information may be submitted in any form desired. Optional Form WH-347 is available for this purpose from the Wage and Hour Division Web site at

<http://www.dol.gov/esa/whd/forms/wh347instr.htm> or its successor site. The Contractor is responsible for the submission of copies of payrolls by all subcontractors. Contractors and subcontractors shall maintain the full social security number and current address of each covered worker, and shall provide them upon request to the Authority if the agency is a party to the contract, but the agency is not such a party, the contractor will submit them to the applicant, sponsor, or owner, as the case may be, for transmission to the (write in name of agency), the contractor, or the Wage and Hour Division of the Department of Labor for purposes of an investigation or audit of compliance with prevailing wage requirements. It is not a violation of this section for a prime contractor to require a subcontractor to provide addresses and social security numbers to the prime contractor for its own records, without weekly submission to the sponsoring government agency (or the applicant, sponsor, or owner).

(b) Each payroll submitted shall be accompanied by a "Statement of Compliance," signed by the Contractor or subcontractor or his or her agent who pays or supervises the payment of the persons employed under the Contract and shall certify the following:

(i) That the payroll for the payroll period contains the information to be provided under §5.5(a)(3)(ii) of Regulations, 29 CFR Part 5, the appropriate information is being maintained under §5.5(a)(3)(i) of Regulations, 29 CFR Part 5, and that such information is correct and complete;

(ii) That each laborer or mechanic (including each helper, apprentice, and trainee) employed on the Contract during the payroll period has been paid the full weekly wages earned, without rebate either directly or indirectly, and that no deductions have been made either directly or indirectly from the full wages earned, other than permissible deductions as set forth in Regulations, 29 CFR Part 3;

(iii) That each laborer or mechanic has been paid not less than the applicable wage rates and fringe benefits or cash equivalents for the classification of work performed, as specified in the applicable wage determination incorporated into the Contract.

(c) The weekly submission of a properly executed certification set forth on the reverse side of Optional Form WH-347 shall satisfy the requirement for submission of the "Statement of Compliance" required by paragraph (C)(2)(b) of this Section.

(d) The falsification of any of the above certifications may subject the Contractor or subcontractor to civil or criminal prosecution under Section 1001 of Title 18 and Section 231 of Title 31 of the United States Code.

3. The Contractor or subcontractor shall make the records required under paragraph (3)(i) of this Section available for inspection, copying, or transcription by authorized representatives of the Federal Transit Administration or the Department of Labor, and shall permit such representatives to interview employees during working hours on the job. If the Contractor or subcontractor fails to submit the required records or to make them available, the Federal agency may, after written notice to the Contractor, sponsor, applicant, or owner, take such action as may be necessary to cause the suspension of any further payment, advance, or guarantee of funds.

Furthermore, failure to submit the required records upon request or to make such records available may be grounds for debarment action pursuant to 29 CFR 5.12.

D. Apprentices and trainees

1. Apprentices - Apprentices will be permitted to work at less than the predetermined rate for the work they performed when they are employed pursuant to and individually registered in a bona fide apprenticeship program registered with the U.S. Department of Labor, Employment and Training Administration, Bureau of Apprenticeship and Training, or with a State Apprenticeship Agency recognized by the Bureau, or if a person is employed in his or her first 90 days of probationary employment as an apprentice in such an apprenticeship program, who is not individually registered in the program, but who has been certified by the Bureau of Apprenticeship and Training or a State Apprenticeship Agency (where appropriate) to be eligible for probationary employment as an apprentice. The allowable ratio of apprentices to journeymen on the job site in any craft classification shall not be greater than the ratio permitted to the Contractor as to the entire work force under the registered program. Any worker listed on a payroll at an apprentice wage rate, who is not registered or otherwise employed as stated above, shall be paid not less than the applicable wage rate on the wage determination for the classification of work actually performed. In addition, any apprentice performing work on the job site in excess of the ratio permitted under the registered program shall be paid not less than the applicable wage rate on the wage determination for the work actually performed. Where Contractor is performing construction on a project in a locality other than that in which its program is registered, the ratios and wage rates (expressed in percentages of the journeyman's hourly rate) specified in the Contractor's or subcontractor's registered program shall be observed. Every apprentice must be paid at not less than the rate specified in the registered program for the apprentice's level of progress, expressed as a percentage of the journey hourly rate specified in the applicable wage determination. Apprentices shall be paid fringe benefits in accordance with the provisions of the apprenticeship program. If the apprenticeship program does not specify fringe benefits, apprentices must be paid the full amount of fringe benefits listed on the wage determination for the applicable classification. If the Administrator of the Wage and Hour Division of the U.S. Department of Labor determines that a different practice prevails for the applicable apprentice classification, fringes shall be paid in accordance with that determination. In the event the Bureau of Apprenticeship and Training, or a State Apprenticeship Agency recognized by the Bureau, withdraws approval of an apprenticeship program, the Contractor will no longer be permitted to utilize apprentices at less than the applicable predetermined rate for the work performed until an acceptable program is approved.

2. Trainees - Except as provided in 29 CFR 5.16, trainees will not be permitted to work at less than the predetermined rate for the work performed unless they are employed pursuant to and individually registered in a program which has received prior approval, evidenced by formal certification by the U.S. Department of Labor, Employment and Training Administration. The ratio of trainees to journeymen on the job site shall not be greater than permitted under the plan approved by the Employment and Training Administration. Every trainee must be paid at not less than the rate specified in the approved program for the trainee's level of progress, expressed as a percentage of the journeyman hourly rate specified in the applicable wage determination. Trainees shall be paid fringe benefits in accordance with the provisions of the trainee program. If the

trainee program does not mention fringe benefits, trainees shall be paid the full amount of fringe benefits listed on the wage determination unless the Administrator of the Wage and Hour Division determines that there is an apprenticeship program associated with the corresponding journeyman wage rate on the wage determination which provides for less than full fringe benefits for apprentices. Any employee listed on the payroll at a trainee rate who is not registered and participating in a training plan approved by the Employment and Training Administration shall be paid not less than the applicable wage rate on the wage determination for the classification of work actually performed. In addition, any trainee performing work on the job site in excess of the ratio permitted under the registered program shall be paid not less than the applicable wage rate on the wage determination for the work actually performed. In the event the Employment and Training Administration withdraws approval of a training program, the Contractor will no longer be permitted to utilize trainees at less than the applicable predetermined rate for the work performed until an acceptable program is approved.

3. Equal employment opportunity. The utilization of apprentices, trainees and journeymen under this part shall be in conformity with the equal employment opportunity requirements of Executive Order 11246, as amended, and 29 CFR Part 30.

E. Compliance with Copeland Act requirements

The Contractor shall comply with the requirements of 29 CFR Part 3, which are incorporated by reference in this Contract.

F. Subcontracts

The Contractor or subcontractor shall insert in any subcontracts the clauses contained in 29 CFR 5.5(a)(1) through (10) and such other clauses as the Federal Transit Administration may by appropriate instructions require, and also a clause requiring the subcontractors to include these clauses in any lower tier subcontracts. The Contractor shall be responsible for the compliance by any subcontractor or lower subcontractor with all the contract clauses in 29 CFR 5.5.

G. Contract termination: Debarment

A breach of the contract clauses in 29 CFR 5.5 may be grounds for termination of the Contract and for debarment as a Contractor and a subcontractor as provided in 29 CFR 5.12.

H. Compliance with Davis-Bacon and Related Act requirements

All rulings and interpretations of the Davis-Bacon and Related Acts contained in 29 CFR Parts 1, 3, and 5 are herein incorporated by reference in this Contract.

I. Disputes Concerning Labor Standards

Disputes arising out of the labor standards provisions of this Contract shall not be subject to the general disputes clause of this Contract. Such disputes shall be resolved in accordance with the procedures of the Department of Labor set forth in 29 CFR Parts 5, 6, and 7. Disputes within the meaning of this clause include disputes between the

Contractor (or any of its subcontractors) and the contracting agency, the U.S. Department of Labor, or the employees or their representatives.

J. Certification of eligibility

1. By entering into this Contract, the Contractor certifies that neither it (nor he or she) nor any person or firm who has an interest in the Contractor's firm is a person or firm ineligible to be awarded Government contracts by virtue of section 3(a) of the Davis-Bacon Act or 29 CFR 5.12(a)(1).
2. No part of this Contract shall be subcontracted to person or firm ineligible for an award of a government contract by virtue of section 3(a) of the Davis-Bacon Act or 29 CFR 5.12(a)(1).
3. The penalty for making false statements is prescribed in the U.S. Criminal Code, 18 U.S.C. 1001.

**O. CONTRACT WORK HOURS AND SAFETY STANDARDS ACT.**

A. Overtime Requirements – Neither the Contractor nor its subcontractors may permit any laborer or mechanic in any workweek in which he or she is employed on such work under this Contract to work in excess of forty (40) hours in such workweek unless such laborer or mechanic receives compensation at a rate not less than one and one-half times the basic rate of pay for all hours worked in excess of forty hours in such workweek.

B. Violation, Liability for Unpaid Wages, Liquidated Damages – In the event of any violation of the clause set forth in paragraph A of this Section, the Contractor and any subcontractor responsible therefor shall be liable for the unpaid wages. In addition, Contractor and subcontractor shall be liable to the United States for liquidated damages. Such liquidated damages shall be computed with respect to each individual laborer or mechanic, including watchmen and guards, employed in violation of the clause set forth in paragraph A of this Section in the sum of \$25,000.00 for each calendar day on which such individual was required or permitted to work in excess of the standard workweek of forty (40) hours without payment of the overtime wages required by the clause set forth in paragraph A of this Section.

C. Withholding for Unpaid Wages and Liquidated Damages – Authority shall upon its own action or upon written request of an authorized representative of the Department of Labor withhold or cause to be withheld from any moneys payable on account of work performed by Contractor under any such contract or any other Federal contract with Contractor or any other federally assisted contract subject to the Contract Work Hours and Safety Standards Act, which is held by Contractor, such sums as may be determined to be necessary to satisfy any liabilities of Contractor or subcontractor for unpaid wages and liquidated damages as provided in the clause set forth in paragraph B of this Section.

D. Subcontracts – The Contractor shall insert in any subcontract the clauses set forth in this Section and also a clause requiring the subcontractors to include these clauses in any lower tier subcontracts. The Contractor shall be responsible for

compliance by any subcontractor or lower tier subcontractor with the clauses set forth in this Section.

E. Payrolls and Basic Records – Payrolls and basic records relating thereto shall be maintained by the Contractor during the course of the work and preserved for a period of three (3) years thereafter for all laborers and mechanics working at the site of the work (or under the United States Housing Act of 1937, or under the Housing Act of 1949, in the construction or development of the project). Such records shall contain the name, address, and social security number of each such worker, his or her correct classification, hourly rates of wages paid (including rates of contributions or costs anticipated for bona fide fringe benefits or cash equivalents thereof of the types described in Section 1(b)(2)(B) of the Davis-Bacon Act), daily and weekly number of hours worked, deductions made and actual wages paid. Whenever the Secretary of Labor has found under 29 CFR 5.5(a)(1)(iv) that the wages of any laborer or mechanic include the amount of any costs reasonably anticipated in providing benefits under a plan or program described in Section 1(b)(2)(B) of the Davis-Bacon Act, the Contractor shall maintain records that show that the commitment to provide such benefits is enforceable, that the plan or program is financially responsible, and that the plan or program has been communicated in writing to the laborers or mechanics affected, and shall also maintain records that show the costs anticipated or the actual cost incurred in providing such benefits. Should the Contractor employ apprentices or trainees under approved programs, it shall maintain written evidence of the registration of apprenticeship programs and certification of trainee programs, the registration of the apprentices and trainees, and the ratios and wage rates prescribed in the applicable programs.

F. Occupational Safety and Health Act – The Contractor agrees to comply with Section 107 of the Contract Work Hours and Safety Standards Act, 40 U.S.C. Section 333, and applicable DOL regulations, “Safety and Health Regulations for Construction”, 29 CFR Part 1926. Among other things, the Contractor agrees that it will not require any laborer or mechanic to work in unsanitary, hazardous, or dangerous surroundings or working conditions.

G. The Contractor also agrees to include the requirements of this Subsection F in each subcontract. The term “subcontract” under this Subsection is considered to refer to a person who agrees to perform any part of the labor or material requirements of a contract for construction, alteration or repair. A person who undertakes to perform a portion of a contract involving the furnishing of supplies or materials will be considered a “subcontractor” under this Section if the work in question involves the performance of construction work and is to be performed: (1) directly on or near the construction site, or (2) by the employer for the specific project on a customized basis. Thus, a supplier of materials that will become an integral part of the construction is a “subcontractor” if the supplier fabricates or assembles the goods or materials in question specifically for the construction project and the work involved may be said to be construction activity. If the goods or materials in question are ordinarily sold to other customers from regular inventory, the supplier is not a “subcontractor.” The requirements of this Section do not apply to contracts or subcontracts for the purchase of supplies or materials or articles normally available on the open market.



**P. INCORPORATION OF FEDERAL TRANSIT ADMINISTRATION (FTA) TERMS**

The preceding provisions include, in part, certain Standard Terms and Conditions required by U.S. DOT, whether or not expressly set forth in the preceding contract provisions. All contractual provisions required by the U.S. DOT, as set forth in FTA Circular 4220.1F, dated November 1, 2008 as may be amended, are hereby incorporated by reference. Anything to the contrary herein notwithstanding, all FTA mandated terms shall be deemed to control in the event of a conflict with other provisions contained in this Contract. The Contractor shall not perform any act, fail to perform any act, or refuse to comply with any the Authority requests which would cause the Authority to be in violation of the FTA terms and conditions.

**22. NOTICES**

Except for invoices submitted by Contractor pursuant to Article 4, all notices or other communications to either party by the other shall be deemed given when made in writing and delivered or mailed to such party at their respective addresses as follows:

To Authority:

Executive Director  
Livermore Amador Valley Transit Authority  
1362 Rutan Court  
Suite 100  
Livermore, CA 94551

To Contractor :

**23. LAWS AND REGULATIONS**

Contractor shall comply with its standard of care with regard to any and all laws, statutes, ordinances, rules, regulations and procedural requirements of any national, state or local government and of any agency of such government, including Authority, which relate to or in any manner affect the performance of this Agreement. This Agreement and any related documents supplied hereunder are subject to the California Public Records Act.

**24. CHOICE OF LAW**

All questions pertaining to the validity and interpretation of this Agreement shall be determined in accordance with the laws of California applicable to agreements made and to be performed within the state.

**25. FORCE MAJEURE**

It is expressly agreed that if the Contractor shall be delayed or interrupted in the performance or completion of its work hereunder by any act, neglect or default of the Authority, or of any employee of the owner, or of any other Contractor employed by the Authority, or by an embargo, war, fire, flood, earthquake,

epidemic or other calamity, act of God or of the public enemy, governmental act (including, but not restricted to, any government priority, preference, requisition, allocation, interference, restraint or seizure, or the necessity of complying with any governmental order, directive, ruling or request) or by any strike or labor dispute involving the Authority, or any manufacturer, supplier or carrier of the machinery, materials or supplies required hereunder, then the time of completion specified herein shall be extended for a period equivalent to the time lost as a result thereof.

**26. ENTIRE AGREEMENT**

This Agreement is the entire agreement of the parties. Contractor represents that in entering into this Agreement, it has not relied on any previous representations, inducements or understandings of any kind or nature.

**27. SEVERABILITY**

If any provision, or any portion of any provision, of any contract resulting from this proposal shall be held invalid, illegal or unenforceable, the remaining provisions or portions of any provisions shall be valid and enforceable to the extent possible.

**28. BENEFIT OF AGREEMENT**

This Agreement shall bind and benefit the parties hereto and their heirs, successors and permitted assigns.

**29. ATTORNEY'S FEES AND OTHER FEES**

Should either party institute any action to enforce this Agreement, or any provision hereof, the prevailing party in any such action or proceeding shall be entitled to receive from the other party all costs and expenses, including reasonable attorney's fees.

IN WITNESS WHEREOF, this Agreement has been executed by the parties hereto as of the day and year first written above.

**THE LIVERMORE AMADOR VALLEY  
TRANSIT AUTHORITY**

\_\_\_\_\_  
Executive Director

Date: \_\_\_\_\_

\_\_\_\_\_  
By\*

\_\_\_\_\_  
Title

\_\_\_\_\_  
By\*

\_\_\_\_\_  
Title

Date: \_\_\_\_\_

**APPROVED AS TO FORM:**

By: \_\_\_\_\_  
Attorney for the Authority

\*If Contractor is a corporation, two corporate officers must sign on behalf of the corporation as follows: (1) Chairman of the Board, President, or Vice President; and (2) Secretary, Assistant Secretary, Chief Financial Officer, or Assistant Financial Officer. In the alternative, this Contract may be executed by a single officer or a person other than an officer provided that evidence satisfactory to LAVTA is provided, demonstrating that such individual is authorized to bind the corporation (e.g., a copy of a certified resolution from the corporation's board or a copy of the corporation's by laws).